

COUNCIL ACTION FORM

SUBJECT: AUTHORIZATION TO SUBMIT NUTRIENT REDUCTION FEASIBILITY STUDY FINAL REPORT TO IOWA DEPARTMENT OF NATURAL RESOURCES

BACKGROUND:

In early 2013 the State of Iowa adopted the Iowa Nutrient Reduction Strategy. The Executive Summary of the Strategy describes the purpose and goals of the Strategy as follows:

“The Iowa Nutrient Reduction Strategy is a science and technology-based framework to assess and reduce nutrients to Iowa Waters and the Gulf of Mexico. It is designed to direct efforts to reduce nutrients in surface water from both point and nonpoint sources in a scientific, reasonable and cost-effective manner.

“Its development was prompted by the 2008 Gulf Hypoxia Action Plan that calls for Iowa and states along the Mississippi River to develop strategies to reduce nutrient loadings to the Gulf of Mexico. The Gulf Hypoxia Action Plan established a goal of at least a 45% reduction in total nitrogen and total phosphorus loads. The strategy will also intensify efforts to address nutrient related water quality problems in Iowa’s waters that negatively impact beneficial water uses enjoyed and required by all Iowans.”

The approximately 150 largest wastewater treatment facilities in the state, both municipal and industrial, are being required to develop a course of action that will lead towards a reduction in their nutrient discharges. The process starts by conducting a feasibility study that looks at:

- The feasibility and reasonableness of reducing the amounts of nitrogen and phosphorus discharged into surface water;
- Identifying the preferred method(s) for reducing total nitrogen and total phosphorus in the final effluent; and
- Identifying a schedule for making operational changes and/or installing new or additional treatment technologies to achieve the nutrient removal goals.

Even though no new NPDES discharge permit has been issued and the obligation to perform a nutrient reduction feasibility study has not formally been imposed by the Iowa Department of Natural Resources, the City chose to perform that evaluation now. The reason was a concern about the remaining life of the trickling filter media. The four filters are packed with corrugated plastic sheeting that provides a surface

for the waste-consuming bacteria to attach to and grow. The plastic modular media is original to the plant construction, and has been in service for 29 years. The media has an assumed life of 20-30 years, and staff estimate a cost in excess of \$10 million to replace the media in the filters. While trickling filters are very good at removing conventional pollutants like biochemical oxygen demand (BOD) and Total Suspended Solids (TSS), they perform poorly at removing nutrients. **As such, staff felt this was a significant financial reason for determining a long-term strategy to comply with the Nutrient Reduction Strategy.**

On April 24, 2018, Council awarded a professional services agreement to HDR Engineers to conduct the feasibility study for the Ames Water Pollution Control Facility (WPCF). On November 20, 2018, City staff along with representatives from HDR presented the conclusions from the feasibility study to the City Council. The final recommendation from the study is that the City should pursue a two-track approach to meet the goals of the Nutrient Reduction Strategy.

- **The first track is to modify the WPCF to achieve the targeted 67% reduction in Total Nitrogen and 75% reduction in Total Phosphorus, with the implementation being phased in over a period of 20 years at a total estimated cost of \$39.6 million.** The phased approach allows existing infrastructure with remaining useful life to be fully utilized before being replaced. It also allows for the facility's capacity to be expanded over time to accommodate growth in the Ames community.
- **The second track is to pursue watershed-based Best Management Practices (such as wetlands, buffer strips, cover crops, stream bank stabilization and similar land practices).** These practices will not reduce the size or scope of the mechanical upgrades at the WPCF. However, staff believes that the nutrient reduction from these sorts of projects will ultimately be able to be "banked" in the newly created Iowa Nutrient Reduction Exchange, and be available as an offset for any further reductions in the nutrient standards in the future.

Projects that would be pursued under this track would be those that would offer additional ancillary benefits in addition to nutrient reduction. Potential ancillary benefits would vary by project, but could include things like flood mitigation; drinking water source protection; new or improved recreational opportunities; improved or restored wildlife habitat; and water quality benefits beyond nutrient reduction.

HDR has now completed the final report, which is ready to be submitted to the Iowa Department of Natural Resources. A copy of the full submittal is attached, along with a brief "lay summary" of the report.

It is important for Council to know that once the report has been reviewed and accepted by the Iowa Department of Natural Resources, the recommendations included in the first track (a three-phase, \$39.6 million treatment modification of the

facility over the next 20 years) will be incorporated into future NPDES permits for the Ames WPCF. Thus, the City will be making a binding commitment to implement these steps.

The final report has been drafted in such a way that the City is not making an irrevocable commitment to the second track (off-site modifications), and is not agreeing to their inclusion as a mandatory element in future NPDES permits. The report states the following regarding this second track:

“The City anticipates that this will be an on-going element of its Capital Improvements Plan, but is not proposing or committing to it as a part of its formal response to addressing nutrients in its discharge.”

This approach preserves the ability for those funds to be redirected to other needs should something of a higher importance arise.

ALTERNATIVES:

1. Adopt a resolution authorizing staff to submit the Ames Nutrient Reduction Feasibility Study Final Report to the Iowa Department of Natural Resources. **Once reviewed and accepted by the Iowa Department of Natural Resources, the City will be committed to implementing the treatment works modifications recommended in the report.**
2. Provide direction to staff to make modifications to the Ames Nutrient Reduction Feasibility Study prior to submitting it to the Iowa DNR.
3. Direct staff not to submit the report at this time. Until a new NPDES permit is issued by the State, the City does not have a formal obligation to submit a study. **However, delaying submission of the report could result in the Iowa DNR requiring that the report be updated with additional data if the submission is delayed.**

CITY MANAGER’S RECOMMENDED ACTION:

The City’s consultant has completed a formal nutrient reduction feasibility study that includes the recommendations shared with Council at the November 20, 2018 workshop. The final report from that study is ready to be submitted to the Iowa Department of Natural Resources in fulfillment of the City’s eventual obligation to perform a study and submit the results to the IDNR.

Therefore, it is the recommendation of the City Manager that the City Council adopt Alternative #1 directing staff to submit the Ames Nutrient Reduction Feasibility Study Final Report to the Iowa Department of Natural Resources. **It is important to reiterate that, once accepted by the State, the recommendation to undertake a three-phase, \$39.6 million modification to the WPCF over the next 20 years will become a binding**

requirement in future NPDES permits for the Ames WPCF. The off-site improvements are included in the final report as a non-binding commitment by the City.

Attachment A: Lay Summary

Attachment B: Final Report – to be submitted to IDNR



CITY OF AMES

Nutrient Reduction Feasibility Study

FEBRUARY 2019



NUTRIENT REDUCTION FEASIBILITY STUDY

The existing Ames Water Pollution Control Facility (WPCF) went into initial operation in 1989. It has and continues to meet National Pollutant Discharge Elimination Permit (NPDES) requirements.

As the Ames WPCF approaches 30 years in age, it faces two major challenges.

- More stringent regulatory requirements to remove the nutrients nitrogen and phosphorus as required in Iowa's 2013 Nutrient Reduction Strategy
- The age, condition, and remaining useful life of the four existing trickling filters that are the heart of the treatment process



This Summary of the Ames WPCF Nutrient Reduction Feasibility Study provides:

- A brief overview of work completed by HDR in collaboration with the City of Ames (City) Water Pollution Control staff in 2018.
- A cost-effective plan to address both challenges facing the Ames WPCF while providing additional capacity for the future.

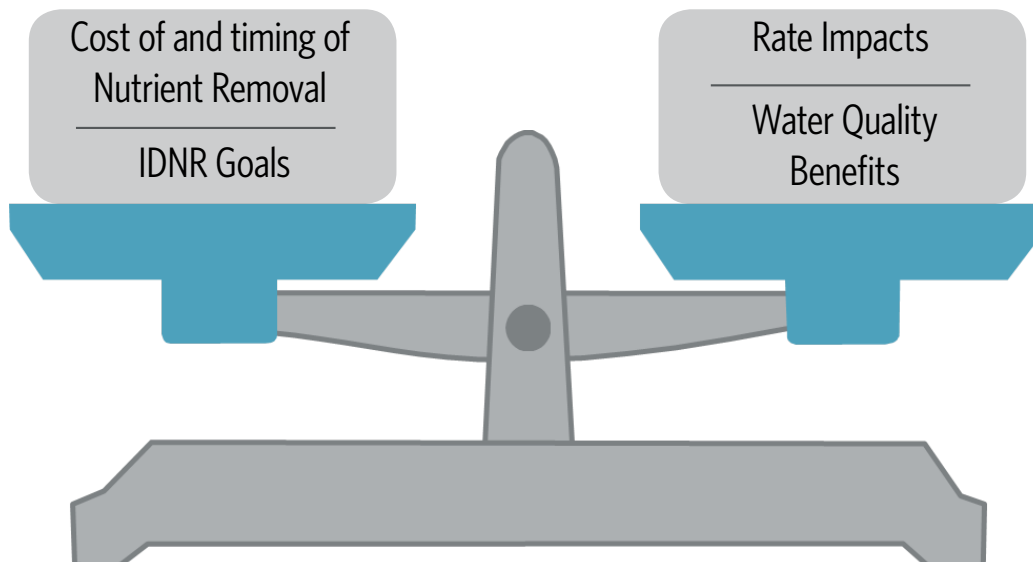

The resulting plan recommends both off-site watershed nutrient reductions and on-site Ames WPCF nutrient reductions. In doing so, it balances the cost and timing of nutrient reduction to achieve Iowa Department of Natural Resources (IDNR) goals with customer rate impacts and associated water quality benefits.

DRIVERS

The primary driver for the Ames WPCF Nutrient Reduction Feasibility Study is the 2013 Iowa Nutrient Reduction Strategy which is part of a broader regional plan to address nutrient related issues; both water quality related hypoxic issues in the Gulf of Mexico and water quality issues in local watersheds. The Nutrient Reduction Strategy targets 45 percent reductions in nitrogen and phosphorus leaving the State. It does so through a) required reductions at wastewater treatment plants, like the Ames WPCF, referred to as point sources and b) voluntary reductions in rural and urban watersheds, referred to as nonpoint sources, through implementation of best management practices.

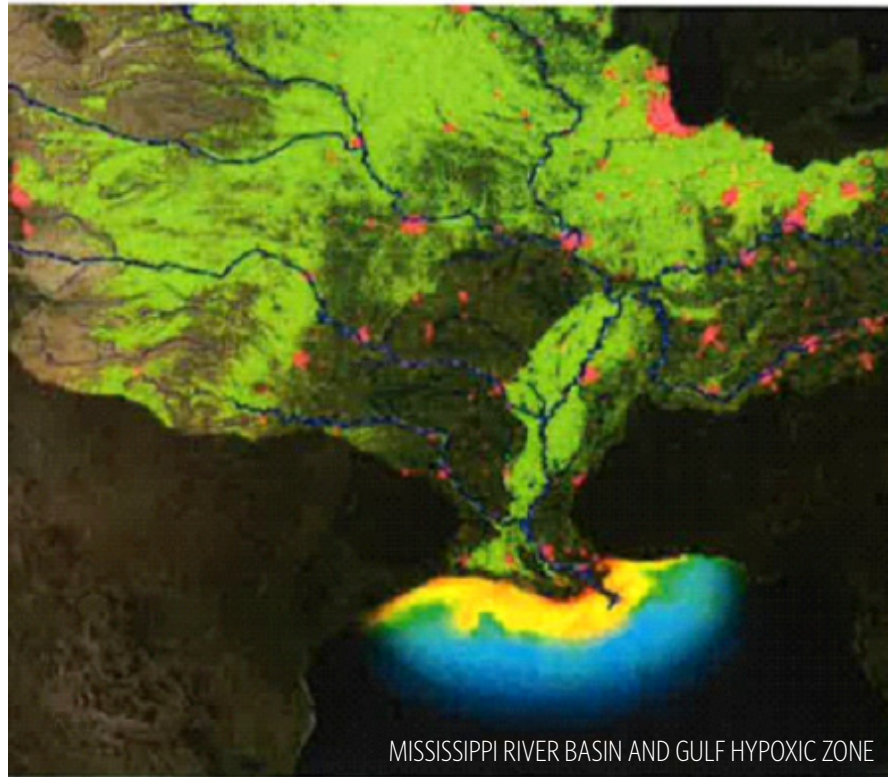

MISSISSIPPI RIVER BASIN AND GULF HYPOXIC ZONE

A second driver for the Ames WPCF Nutrient Reduction Feasibility Study is the age, condition, and remaining useful life of the four existing trickling filters that are the heart of the Ames WPCF.



EXISTING TRICKLING FILTERS



MEDIA INSIDE



EXTERIOR STRUCTURE

The trickling filters have performed exceedingly well for their original design purpose, but both the exterior structure and the interior media are approaching the end of their useful life. The existing trickling filters would cost an estimated \$8.8 million to replace, and would provide limited value treatment process wise with respect to the biological nutrient removal required by the 2013 Iowa Nutrient Reduction Strategy.

EXISTING AMES WPCF

The existing Ames WPCF is a trickling filter solids contact facility that treats an average daily flow of 6.19 million gallons per day, the equivalent of nearly 700 tanker trucks per day. The facility is designed to treat organic loadings (biochemical oxygen demand and total suspended solids) and ammonia. It was not designed to remove nutrients, but does currently remove approximately 42 percent of the nitrogen and 25 percent of the phosphorus. Both are less than the 66 percent nitrogen and 75 percent phosphorus reductions required by the Iowa Nutrient Reduction Strategy

EXISTING AMES WPCF AVERAGE FLOWS AND LOADS

Parameter	Average
Flow, Million Gallons per Day	6.19
Biochemical Oxygen Demand, Pounds per Day	9,360
Total Suspended Solids, Pounds per Day	11,000
Ammonia, Pounds per Day	1,300
Nitrogen, Pounds per Day	2,050
Phosphorus, Pounds per Day	263

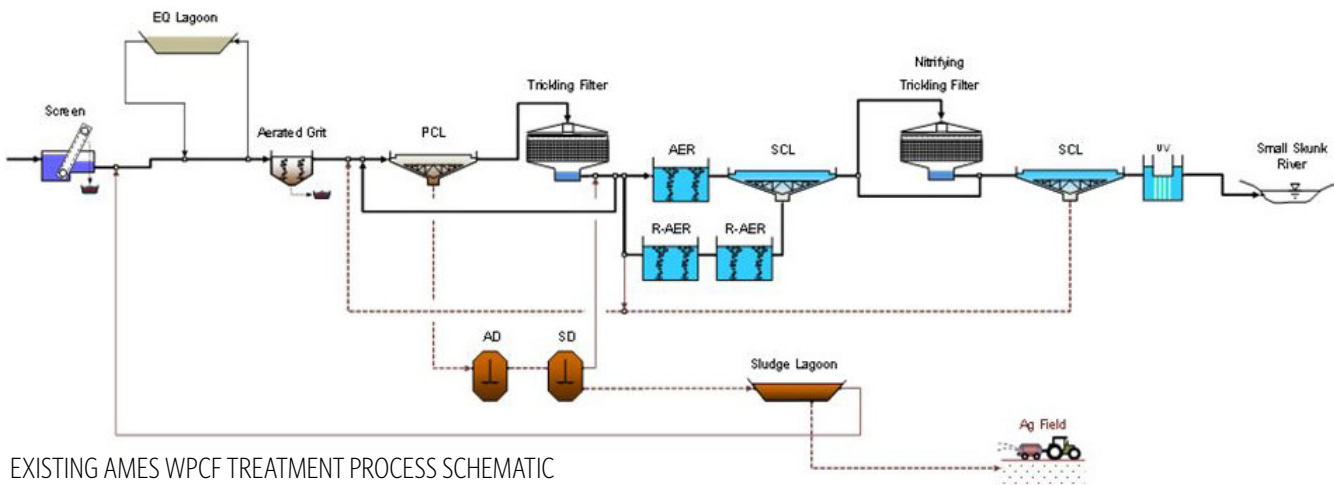

EXISTING AMES WPCF TREATMENT PROCESS SCHEMATIC



RECOMMENDED PLAN

The recommended plan to achieve the nutrient reductions required by the Iowa Nutrient Reduction Strategy was developed based on the following.

- ✓ Rigorous analysis of current and forecast future flows and loadings on the Ames WPCF
- ✓ Thorough assessment of existing WPCF performance capabilities
- ✓ Extensive quantification of nutrient sources throughout the watershed including influent to the WPCF
- ✓ Identification, screening, development, and evaluation of multiple watershed and WPCF nutrient reduction alternatives.

The recommended plan will transition the Ames WPCF from an existing trickling filter solids contact process to a future biological nutrient reduction process, incorporating one of three alternative technologies, simultaneous nitrification denitrification, carbonaceous activated sludge, or granular activated sludge. When complete, the Ames WPCF will provide capacity for projected growth and progressively achieve compliance with the 2013 Iowa Nutrient Reduction Strategy. The specific biological nutrient removal technology will be determined at the beginning of the first phase of implementation since all three alternative technologies are comparable in cost and merit.

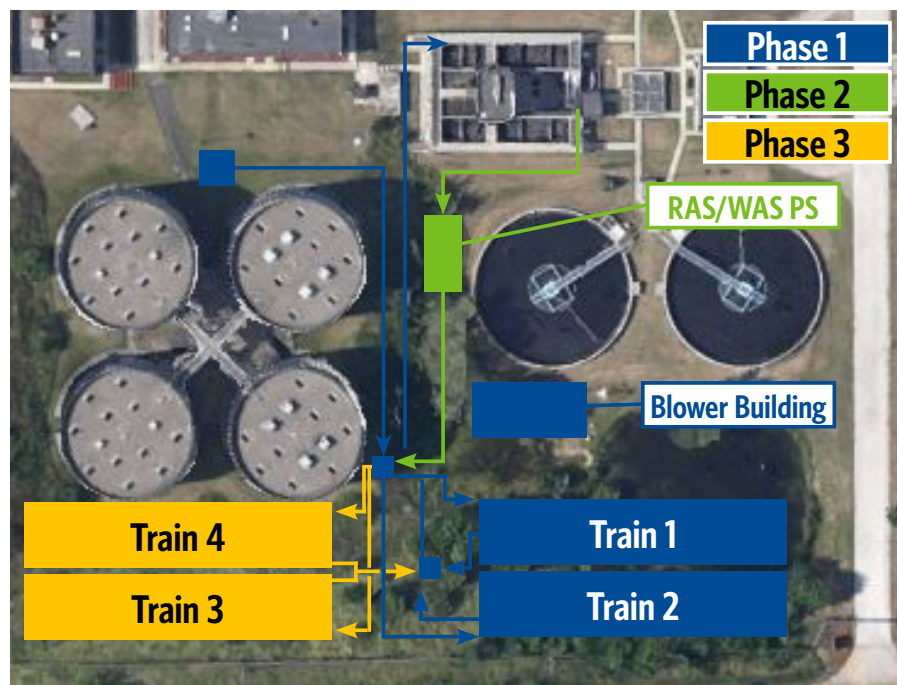

FUTURE BIOLOGICAL NUTRIENT REMOVAL

With implementation of the recommended plan, the Ames WPCF will progressively increase from current maximum month flows and loadings to projected future influent maximum month capacities as follows:

- 12.6 million to 15.7 million gallons per day flow
- 12,100 to 16,600 pounds per day 5-day biochemical oxygen demand
- 16,300 to 22,400 pounds per day total suspended solids
- 1,680 to 2,300 pounds per day ammonia
- 2,340 to 3,210 pounds per day total nitrogen
- 299 to 410 pounds per day total phosphorus

Limited, if any, nutrient reduction will be achieved in Phase 1, seasonal reduction will be achieved in Phase 2, and full biological nutrient reduction will be achieved in Phase 3. Two factors drive this progressive reduction. First, the need to take advantage of prior investment and the remaining useful life of the existing trickling filters while providing reliable capacity for growth. Second, the configuration of the existing Ames WPCF prevents separate parallel operation of the existing trickling filters and new alternative technology.

The recommended plan also includes a parallel track to continue to incorporate stormwater best management practices in public works projects and target additional off site watershed nutrient reduction projects to demonstrate commitment and progress toward the 2013 Iowa Nutrient Reduction Strategy. Projects will be targeted that achieve nutrient reduction in conjunction with other ancillary benefits such as flood mitigation, source water protection, erosion control, habitat restoration, water quality, and recreation.

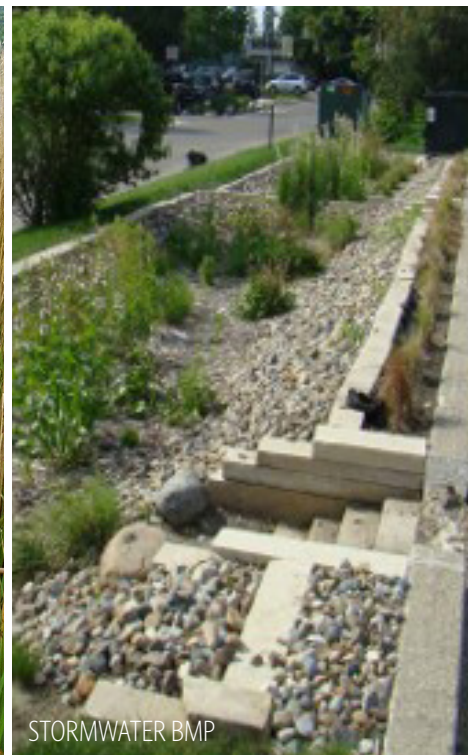

Example sites have been identified and grouped by location on City Property, within the City, and upstream of the City. Example projects include bioreactors, constructed wetlands, conservation reserve, research, hydraulic modifications, stormwater detention, and riparian buffer. The City's future Capital Improvements Plan includes \$200,000 per year for use in conjunction with available grant funding for these types of projects. Nutrient reductions will be registered with the Iowa Nutrient Reduction Exchange as potential offsets to more stringent future requirements at the Ames WPCF.

IMPLEMENTATION

The estimated capital cost, including both engineering and construction, and timing for each phase of the recommended plan at the Ames WPCF is presented below. It is noteworthy that the estimate does not include any additional capital investment in the existing trickling filters to prolong their remaining useful life. The recommended plan will be implemented in 3 phases over the next 20 years at an estimated cost of \$30.5 million. Inflated to the actual construction periods, the estimated cumulative capital cost for all three phases is \$39.63 million.

PHASE 1	<p>\$10.20 million (\$8.5 million in 2018 dollars)</p> <p>1st - 5 years</p>	<ul style="list-style-type: none"> • Keep Trickling Filters in Services • Incorporate 1st Phase of Alternative Technology • Provides Redundant and some Growth Capacity (Current Permit Limits) • Provides Limited, if Any, Nutrient Reduction
PHASE 2	<p>\$14.26 million (\$11 million in 2018 dollars)</p> <p>2nd - 5 years</p>	<ul style="list-style-type: none"> • Take Trickling Filters Out of Services as they Fail • Incorporate 2nd Phase of Alternative Technology • Provides Additional / Redundant Capacity • Provides Seasonal Biological Nutrient Reduction
PHASE 3	<p>\$15.17 million (\$11 million in 2018 dollars)</p> <p>Last - 10 years</p>	<ul style="list-style-type: none"> • Take Remaining Trickling Filters Out of Service • Incorporate 3rd Phase of Alternative Technology • Provides Forecast 2040 Treatment Capacity • Provides Full Biological Nutrient Reduction

Water and sewer are on the same utility bill, so the timing of rate adjustments are coordinated to avoid doubling up in a single year and projected for 10 years to provide a long-term picture where utility rates are heading. The 10-year plan presented to City Council spring shows 5- or 6-percent sewer rate increases in alternating years to pay for the recommended nutrient plan along with other ongoing needs.

TEN YEAR PLAN FOR PROPOSED AMES WATER AND SEWER RATE INCREASES										
	Year 1	Year 2	Year 3	Year 4	Year 5	Year 6	Year 7	Year 8	Year 9	Year 10
	19-20	20-21	21-22	22-23	23-24	24-25	25-26	26-27	27-28	28-29
Water Fund	7%		9%		9%		9%		9%	
Sewer Fund		5%		5%		6%		6%		5%

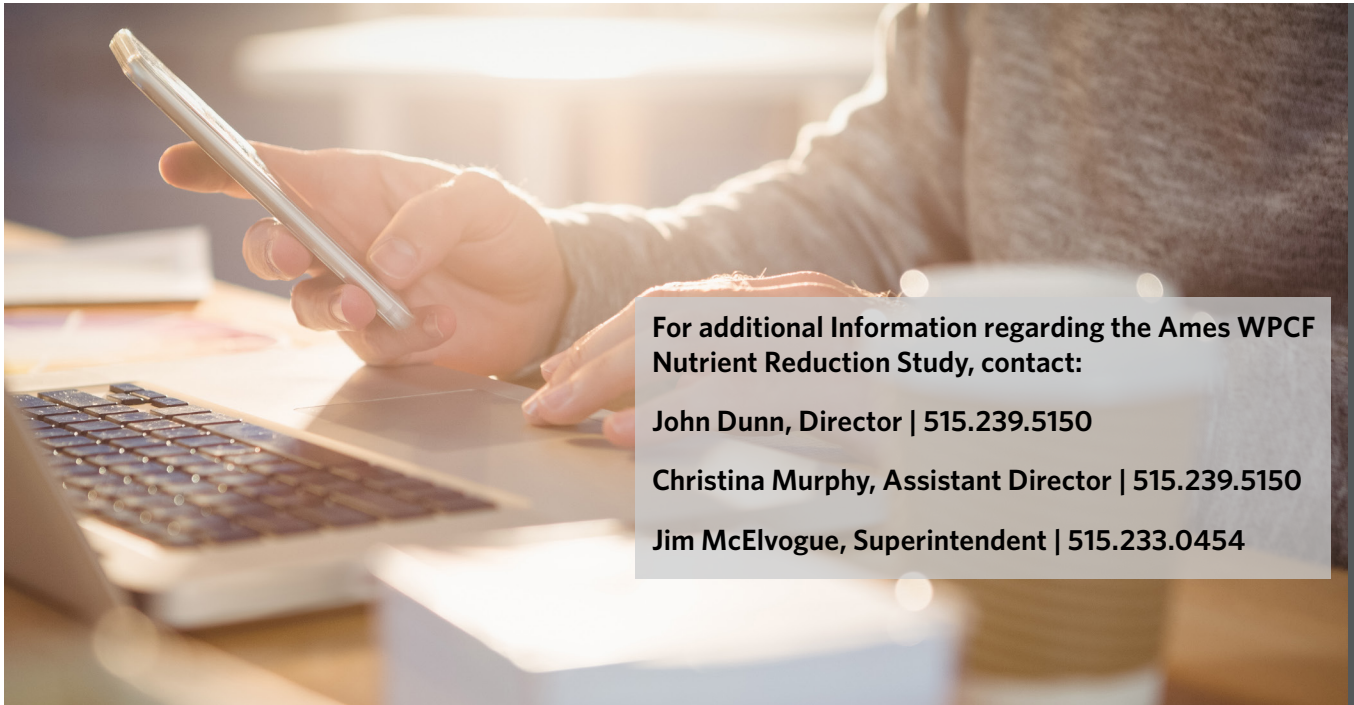

**For additional information regarding the Ames WPCF
Nutrient Reduction Study, contact:**

John Dunn, Director | 515.239.5150

Christina Murphy, Assistant Director | 515.239.5150

Jim McElvogue, Superintendent | 515.233.0454

Ames Nutrient Reduction Feasibility Study

February 14, 2019

Prepared for



This page intentionally left blank.

Water Pollution Control Facility

Nutrient Reduction Feasibility Study



Final

February 14, 2019

A circular professional engineer seal for David M. Dechant, License No. 13723, State of Iowa. The seal contains the text 'LICENSED PROFESSIONAL ENGINEER' around the top edge, 'DAVID M. DECHANT' and '13723' in the center, and 'IOWA' at the bottom.	<p>Certification of the Engineer of Record I hereby certify these documents were prepared by me, or under my direct personal supervision, and I am a duly Licensed Professional Engineer under the laws of the State of Iowa.</p> <hr/> <p>David Dechant 02/14/2019 Iowa License No. P13723 My License Renewal Date is 12/31/2019</p>
--	---

HDR Engineering, Inc. 2019



Acknowledgements:

This document reflects the collaborative efforts and input of the following Project Team

City of Ames WPC

*Dustin Albrecht
John Dunn
Kris Evans
Joe Krebs
Jim McElvogue
Christina Murphy
Maryann Ryan
Tyler VerMeer
Tracy Warner
Neil Weiss*

HDR Engineering

*Brian Bakke
Mario Benisch
John Christiansen
David Dechant
Nikki Dietze
JB Neethling
Trent Stober*

FOX Engineering

Lance Aldrich

Prairie Rivers of Iowa

Dan Haug

Contents

1	Introduction	1
2	Summary	2
3	Existing Treatment Facility	4
3.1	Raw and Effluent Data	8
3.2	Nutrient Reduction Capability.....	11
4	Nutrient Baseline.....	12
5	Ames WPCF Nutrient Reduction.....	15
5.1	Ames WPCF Source Reduction	15
5.2	Solids Recycle Management.....	16
5.3	Ames WPCF Operation Changes	18
5.4	Ames WPCF Treatment Technologies.....	20
5.4.1	Alternatives Identification and Screening	20
5.4.2	Key Findings and Ames WPCF Strategy.....	24
5.4.3	Alternatives Development and Evaluation.....	24
6	Watershed Nutrient Reductions	30
6.1.1	Potential Practices	30
6.1.2	Key Findings and Strategy.....	32
6.1.3	Watershed Alternatives.....	33
6.2	Integrated Strategy and Implementation	40
6.3	Integrated Nutrient Reduction Strategy	40
6.4	Implementation Plan	40
6.4.1	Sewer Rate Impacts.....	42

Tables

Table 1: Ames WPCF Existing Unit Processes	6
Table 2: Ames WPCF NPDES Permit Limits: 5-day Carbonaceous Biochemical Oxygen Demand	7
Table 3: Ames WPCF NPDES Permit Limits: Total Suspended Solids.....	8
Table 4: Ames WPCF NPDES Permit Limits: Ammonia-Nitrogen.....	8
Table 5: Ames WPCF NPDES Permit Limits: Acute Toxicity, Pimephales.....	8
Table 6: Ames WPCF Current and Projected Influent Wastewater Flows and Loads	9
Table 7: Effluent Data (January 1, 2015 – December 31, 2017).....	10
Table 8: WPCF Nutrient Reduction (January 1, 2015 – December 31, 2017).....	11
Table 9: Nutrient Loadings in the South Skunk River Watershed	12

Table 10: Ames WPCF Nutrient Loadings in the South Skunk River Watershed.....	12
Table 11: Improvement Recycle Management Options.....	17
Table 12: Ames WPCF Optimization.....	18
Table 13: Nutrient Reduction Option Effluent Summary.....	19
Table 14: Nutrient Reduction Option Comparative Costs.....	19
Table 15: Alternative Technology.....	20
Table 16: Comparative Costs (\$2018).....	21
Table 17: Nonmonetary Criteria Comparison*.....	23
Table 18: On-site Ames WPCF Nutrient Reduction Strategies.....	24
Table 19: Planning Level Estimated Costs (\$2018).....	28
Table 20: Performance and Cost of Agricultural Best Management Practices.....	31
Table 21: Potential Applicability of Agricultural Best Management Practices.....	31
Table 22: Potential Off-site Nutrient Reduction Strategy.....	33
Table 23: Off-site Nutrient Reduction Prioritization Criteria.....	37
Table 24: Off-site Nutrient Reduction Example Sites and Projects.....	38
Table 25: Integrated Nutrient Reduction Strategy.....	40
Table 26: Ten Year Plan for Ames Water and Sewer Rate Increases.....	43
Table 27: Ames Sewer Rate Increases With and Without Nutrient Reduction Strategy.....	44

Figures

Figure 1: Existing Ames WPCF Aerial Photo.....	4
Figure 2: Existing Ames WPCF Process Schematic.....	4
Figure 3: Existing Trickling Filters.....	5
Figure 4: SPARROW Model Total Nitrogen Nonpoint Source by Area.....	13
Figure 5: SPARROW Model Total Phosphorus Nonpoint Source by Area.....	13
Figure 6: Ames WPCF Nutrient Sources.....	15
Figure 7: Residential and Commercial Phosphorus Sources.....	15
Figure 8: Primary Clarifier and Stage 1 TF effluent TSS.....	17
Figure 9: Ames WPCF Alternative Site Layouts.....	22
Figure 10: Trickling Filter Pump Station.....	25
Figure 11: Alternative Technology Phased Water Surface Elevations.....	26
Figure 12: Ames WPCF Nutrient Reduction Alternatives.....	27
Figure 13: Agricultural Best Management Practices.....	30
Figure 14: Perennial Cover Crop.....	31
Figure 15: Off-site Nutrient Reduction Example Sites and Projects - City Property.....	34
Figure 16: Off-site Nutrient Reduction Example Sites and Projects – Within City.....	35
Figure 17: Off-site Nutrient Reduction Example Sites and Projects – Outside City.....	36
Figure 18: Ames Nutrient Reduction Implementation Plan.....	41
Figure 19: Ames WPCF Nutrient Reduction Implementation Costs (\$2018).....	42

Attachments

Attachment A – Ames WPCF Optimization Options

1 Introduction

The existing Ames Water Pollution Control Facility (WPCF) went into initial operation in 1989. As the Ames WPCF approaches 30 years in age, it faces two significant challenges. Those challenges include the following:

- More stringent regulatory requirements to remove the nutrients nitrogen and phosphorus outlined in the Iowa's 2013 Nutrient Reduction Strategy
- The age, condition, and remaining useful life of the four existing trickling filters that are the heart of the treatment process

The Ames WPCF Nutrient Reduction Feasibility Study documents the work conducted by HDR in collaboration with the City of Ames (City) Water Pollution Control staff, toward finding solutions to those challenges. The study also documents a cost-effective plan to address both challenges while providing additional capacity at the facility for the future.

This document provides a summary of the resulting plan for review and approval by the Iowa Department of Natural Resources (IDNR) even though the obligation to perform a nutrient reduction feasibility study has yet to be incorporated into the City's National Pollution Discharge Elimination System (NPDES) permit. This document is outlined as follows.

- Summary
- Existing Treatment Facility
- Nutrient Baseline
- Ames WPCF Nutrient Reduction
- Watershed Nutrient Reduction
- Integrated Strategy and Implementation
- Attachment A. Ames WPCF Optimization Options

2 Summary

The Ames WPCF Nutrient Reduction Feasibility Study recommends an integrated strategy that comprises off-site watershed nutrient reductions and on-site Ames WPCF nutrient reductions. The integrated strategy balances the cost and timing of nutrient reduction to achieve IDNR goals with customer rate impacts and associated water quality benefits.

The first component of the integrated strategy would transition the Ames WPCF from an existing trickling filter solids contact process to a future biological nutrient reduction process, incorporating one of three alternative technologies: 1) simultaneous nitrification denitrification (SNDN); 2) carbonaceous activated sludge (CAS); or 3) granular activated sludge (GRAS). In doing so, the Ames WPCF would provide capacity for projected flows and loadings and would progressively achieve compliance with the 2013 Iowa Nutrient Reduction Strategy. The transition would occur in three phases over the next 20 years to take advantage of the remaining useful life of existing facilities, most notably the trickling filters. The specific biological nutrient removal technology would be determined at the beginning of the first phase.

The required capital investment, in 2018 dollars, is estimated to be as follows.

- Phase 1: \$8.5 million over the first 5 years
- Phase 2: \$11 million over the next 5 years
- Phase 3: \$11 million over the last 10 years

With this integrated strategy, nutrient reduction at the Ames WPCF would progressively increase from current reductions of approximately 42 percent nitrogen and 25 percent phosphorus to the targeted 2013 Iowa Nutrient Reduction Strategy reductions of 66 percent nitrogen and 75 percent phosphorus, both on an annual average basis. The anticipated progression is outlined in the following.

- Minimal additional removal following Phase 1
- Seasonal biological nutrient removal following Phase 2
- Full biological nutrient removal following Phase 3

The configuration of the existing Ames WPCF and the goal of fully using the remaining useful life of the existing trickling filters precludes using more aggressive nutrient reductions earlier than what is planned with the integrated strategy.

The Ames WPCF would concurrently and progressively increase from current maximum month flows and loadings to projected future influent maximum month capacities as follows:

- 12.6 to 15.7 million gallons per day flow
- 12,100 to 16,600 pounds per day 5-day biochemical oxygen demand (BOD₅)
- 16,300 to 22,400 pounds per day total suspended solids (TSS)
- 1,680 to 2,300 pounds per day ammonia
- 2,340 to 3,210 pounds per day total nitrogen
- 299 to 410 pounds per day total phosphorus

While not specifically Ames WPCF permit related, the second component of the integrated strategy would continue the City's practice to incorporate stormwater best management practices (BMPs) in public works projects and target additional off-site watershed nutrient reduction projects to demonstrate commitment and progress towards nutrient reduction. Likewise, the City anticipates continued collaboration with Iowa State University as they explore additional agricultural BMPs such as perennial cover crops.

The Ames WPCF Nutrient Reduction Feasibility Study identifies example sites and projects to convey the associated concepts and established criteria to prioritize off-site nutrient reduction projects. The associated capital investment is budgeted at \$200,000 per year in the City's fiscal year 2020 *Capital Improvements Plan*. It is anticipated that the City would leverage that amount to obtain additional funding from available state and federal funding sources. Nutrient reductions would be registered with the Iowa Nutrient Reduction Exchange as potential offsets to more stringent future requirements at the Ames WPCF. The City anticipates that this will be an ongoing element of the *Capital Improvements Plan*, but is not proposing or committing to it as part of its formal response to addressing nutrients in the Ames WPCF discharge.

3 Existing Treatment Facility

The Ames WPCF is a trickling filter solids contact (TF/SC) facility (Figure 1) that has been in full operation since 1989. At the facility, raw influent is screened and degritted before being pumped to primary clarification. Wet weather flows in excess of the rated capacity of 20.4 million gallons per day (MGD) are pumped to two, lined 2.2-million-gallon equalization basins. Equalization lagoon content flows back by gravity to the influent pump station when flows drop below the diversion set point and when TF/SC capacity is available. Diversion to the equalization lagoon varies, but usually ranges between 5 and 20 times per year.

During extreme wet weather events, the equalization basins overflow, blending with the disinfected secondary effluent and then discharging to the river. Historically, this has occurred in 6 of the last 11 years. In 3 of those 6 years, the equalization basins overflowed on multiple days, while during the other years the equalization basins overflowed on a single day.

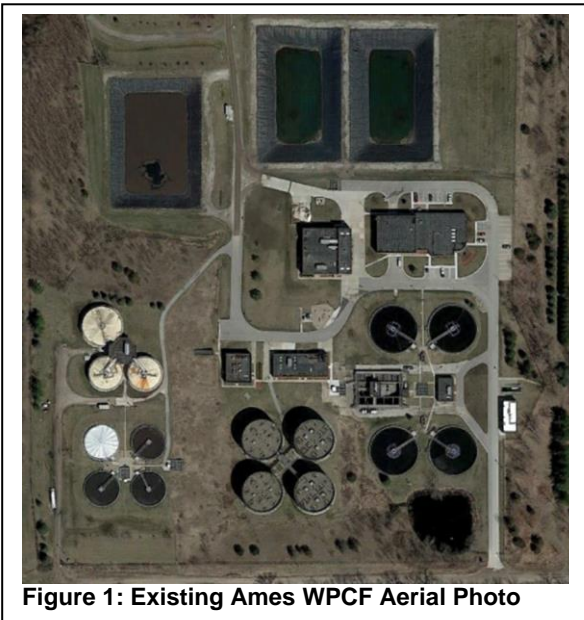

Figure 1: Existing Ames WPCF Aerial Photo

After primary treatment in four, 70-foot diameter clarifiers, primary effluent flows by gravity to the Stage 1 trickling filters for BOD removal. The Stage 1 trickling filter effluent flows to the solids contact tanks for polishing and flocculation. A portion of the Stage 1 trickling filter effluent is recycled back and combined with primary influent to maintain wetting on the Stage 1 trickling filters. The solids contact effluent enters the intermediate clarifiers and clarified effluent is pumped to the downstream Stage 2 trickling filters before final clarification and disinfection with ultraviolet light.

Figure 2 shows a simplified process schematic for the Ames WPCF. The solids contact process includes return activated sludge (RAS) reaeration tanks, which help increase the solids holding capacity to improve polishing in the solids contact tank, as well as aid floc formation for better solids settling in the Stage 1 clarifiers.

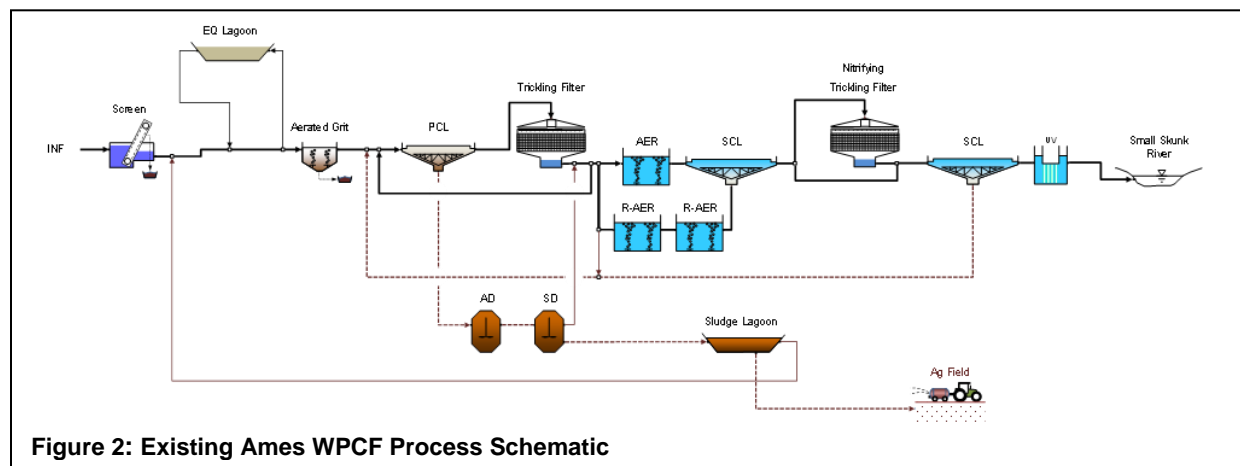
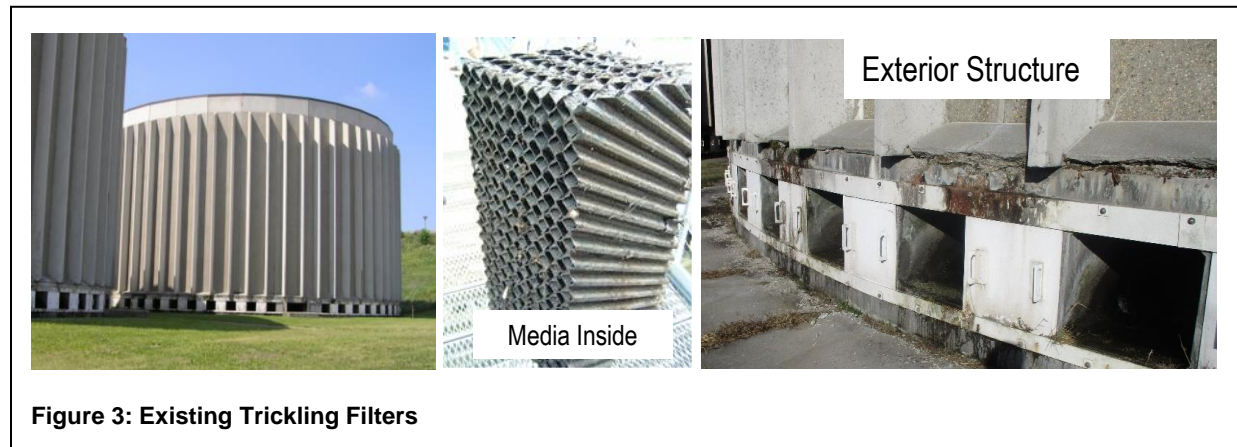

Figure 2: Existing Ames WPCF Process Schematic

Waste activated sludge (WAS) from the intermediate and final clarifiers are pumped to the primary clarifier for co-thickening with primary solids. The thickened solids are pumped to the anaerobic digesters and the digested sludge is stored in a sludge lagoon before liquid land application.

Table 1 provides existing unit process design information. The main constraint of the existing facility is the trickling filters. The trickling filter process is not well suited for biological nutrient removal, which requires anaerobic and anoxic conditions as well as a carbon source. As shown in Figure 3, the structural conditions of the trickling filters has diminished and the media is at or nearing the end of its useful life. With the anticipated nutrient limits in mind, major capital investments to extend the life of the trickling filters are not prudent. Minor improvements and repairs to extend their useful life and provide interim nutrient reduction may be included as necessary.



Most of the existing unit processes and equipment are from original construction completed in 1979. Some pumps have been rebuilt or replaced. Overall, much of the mechanical equipment is approaching 30 years in service and nearing the end of useful life. While the facility remains functional, safe, and in regulatory compliance, the age and condition of the existing equipment translates into ongoing capital investment.

The receiving stream for Ames WPCF effluent is the South Skunk River, with the receiving stretch being designated as Class A(1), B(WW-2), and a 7Q10 stream flow of 0 cubic feet per second (cfs). Current numeric limits for Ames WPCF effluent are shown in Table 2 through Table 5. Limits in the tables include typical secondary standards for carbonaceous biochemical oxygen demand (cBOD) and total suspended solids (TSS), seasonally variable ammonia (NH₃-N) limits, acute toxicity (Pimaphales) requirements, seasonal bacterial (Escherichia coli [E. coli]) limits, pH, and dissolved oxygen (DO).

The Ames WPCF has maintained a 100 percent compliance record with the numeric limits of its permit since becoming fully operational in 1989; a streak that, according to the National Association of Clean Water Agencies, is the second-longest active compliance record in the nation.

Table 1: Ames WPCF Existing Unit Processes

Parameter	Unit	Value
Screens		
Type		1/2 inch Bar
Number of units		2
Capacity each	MGD	16
Firm Capacity	MGD	32
Type		3/8 inch Bar
Number of units		1
Capacity each	MGD	13.3
Grit Removal		
Type		Accelerated Gravity
Capacity	MGD	20.4
Primary Clarifiers		
Number		4
Diameter each	ft	70
Area each	ft ²	3,848
Total Capacity (ave – one unit out of service)	MGD	10.5
Total Capacity (peak)	MGD	38.5
First Stage Trickling Filters		
Number		2
Diameter	ft	80 ft
Media		Plastic Cross Flow
Media Depth	ft	26 ft
Media Specific Area	ft ² /ft ³	30
Total Media Area	ft ²	3.92 x 10 ⁶
Media Volume - Each	ft ³	130,690
Second Stage Trickling Filters		
Number		2
Diameter	ft	80
Media		Plastic Cross Flow
Media Depth	ft	26
Media Specific Area	ft ² /ft ³	50
Total Media Area	ft ²	6.53 x 10 ⁶
Media Volume – Each	ft ³	130,690
Solids Contact Basins		
Number of Basins		2
Number of Cells per Basin		5
Cell Width	ft	18
Cell Length	ft	18
Side Water Depth	ft	15

Parameter	Unit	Value
Total Solids Contact Volume	gal	363,530
Sludge Reaeration Basin		
Number of Basins		2
Number of Cells per Basin		5
Basin Width	ft	14
Basin Length	ft	28
Side Water Depth	ft	15
Total Solids Contact Volume	gal	87,960
Secondary Clarifiers		
Number		4
Diameter	ft	100
Side Water Depth	ft	14
Area	ft ²	7854
Weir Length	ft	298
Disinfection		
Type		UV
Capacity	MGD	25
Primary Digesters		
Number		2
Volume Each	MG	0.72
Secondary Digesters		
Number		1
Volume Each	MG	0.92

Table 2: Ames WPCF NPDES Permit Limits: 5-day Carbonaceous Biochemical Oxygen Demand

Month	Concentration, mg/L			Mass, pounds/day		
	Daily Maximum	7-day Average	Monthly Average	Daily Maximum	7-day Average	Monthly Average
Jan		30.0	20.0		3,027.0	2,018.0
Feb		30.0	20.0		3,027.0	2,018.0
Mar		30.0	20.0		3,027.0	2,018.0
Apr		30.0	20.0		3,027.0	2,018.0
May		30.0	20.0	--	3,027.0	2,018.0
Jun	30.0		20.0	3,027.0		2,018.0
Jul	30.0		20.0	3,027.0		2,018.0
Aug	30.0	--	20.0	3,027.0		2,018.0
Sept	30.0		20.0	3,027.0		2,018.0
Oct		30.0	20.0		3,027.0	2,018.0
Nov		30.0	20.0		3,027.0	2,018.0
Dec		30.0	20.0		3,027.0	2,018.0
%Removal			>85%			>85%

Table 3: Ames WPCF NPDES Permit Limits: Total Suspended Solids

	Concentration, mg/L			Mass, pounds/day		
	Daily Maximum	7-day Average	Monthly Average	Daily Maximum	7-day Average	Monthly Average
Monthly		45.0	30.0		4,541.0	3,027.0
%Removal		--	>85%		-	>85%

Table 4: Ames WPCF NPDES Permit Limits: Ammonia-Nitrogen

Month	Concentration, mg/L			Mass, pounds/day		
	Daily Maximum	7-day Average	Monthly Average	Daily Maximum	7-day Average	Monthly Average
Jan	15.2		5.2	1,533.0		521.0
Feb	14.2		5.7	1,433.0		575.0
Mar	14.7		4.5	1,482.0		454.0
Apr	15.7		2.1	1,584.0		212.0
May	15.2		1.8	1,533.0		182.0
Jun	11.5		1.3	1,161.0		131.0
Jul	8.5		1.1	858.0		109.0
Aug	10.0		1.0	1,009.0		99.0
Sept	16.5		1.5	1,664.0		150.0
Oct	15.7		2.3	1,584.0		232.0
Nov	14.7		3.4	1,482.0		343.0
Dec	16.0		4.0	1,611.0		399.0

Table 5: Ames WPCF NPDES Permit Limits: Acute Toxicity, E. coli, pH, and DO

Parameter / Season	Requirement	
Acute Toxicity	Daily Maximum	
Yearly	No Toxicity (Ceriodaphnia or Pimephales)	
E. coli	Geometric Mean, # cfu / 100 ml	
March through November	126	
pH	Daily Minimum, s.u.	Daily Maximum, s.u.
Yearly	6.5	9.0
Dissolved Oxygen (D.O.)	Daily Minimum	
Yearly	5.0	

3.1 Raw and Effluent Data

Current and projected AMES WPCF influent flows and loads are summarized in Table 6. Ames WPCF effluent data is summarized in Table 7.

Table 6: Ames WPCF Current and Projected Influent Wastewater Flows and Loads

	2015-2017 Data		2020			2025			2030			2035			2040		
		Concentration, mg/L	Residential/ Commercial Growth	Reserve	Total	Residential/ Commercial Growth	Reserve	Total	Residential/ Commercial Growth	Reserve	Total	Residential/ Commercial Growth	Reserve	Total	Residential/ Commercial Growth	Reserve	Total
Flow, MGD																	
Average Annual	6.19	N/A	6.25	0.50	6.75	6.43	0.50	6.93	6.62	1.00	7.62	6.81	1.00	7.81	6.99	1.50	8.49
Maximum Month	12.6*	N/A	12.7	0.50	13.2	13.1	0.50	13.6	13.5	1.00	14.5	13.9	1.00	14.9	14.2	1.50	15.7
Maximum Day	37.2**	N/A	37.5	0.50	38.0	38.7	0.50	39.2	39.8	1.00	40.8	40.9	1.00	41.9	42.0	1.50	43.5
BOD₅, lb/day																	
Average Annual	9,360	181	9,450	800	10,250	9,720	800	10,520	10,000	1,500	11,500	10,300	1,500	11,800	10,600	2,300	12,900
Maximum Month	12,100	115	12,200	1,000	13,200	12,600	1,000	13,600	13,000	1,900	14,900	13,300	1,900	15,200	13,600	3,000	16,600
Maximum Day	18,100	58	18,200	1,500	19,700	18,800	1,500	20,300	19,400	2,900	22,300	19,900	2,900	22,800	20,400	4,400	24,800
TSS, lb/day																	
Average Annual	11,000	213	11,100	900	12,000	11,400	900	12,300	11,800	1,800	13,600	12,100	1,800	13,900	12,400	2,700	15,100
Maximum Month	16,300	155	16,400	1,300	17,700	16,900	1,300	18,200	17,500	2,700	20,200	18,000	2,700	20,700	18,400	4,000	22,400
Maximum Day	31,300	101	31,600	1,700	33,300	32,600	1,700	34,300	33,500	3,500	37,000	34,400	3,500	37,900	35,300	5,200	40,500
Ammonia, lb-N/day																	
Average Annual	1,300	25.2	1,310	110	1,420	1,350	110	1,460	1,390	210	1,600	1,430	210	1,640	1,470	320	1,790
Maximum Month	1,680	16.0	1,690	140	1,830	1,750	140	1,890	1,800	270	2,070	1,850	270	2,120	1,890	410	2,300
Maximum Day	2,360	7.6	2,380	200	2,580	2,460	200	2,660	2,520	380	2,900	2,590	380	2,970	2,660	580	3,240
TKN, lb-N/day																	
Average Annual	2,050	39.7	2,070	170	2,240	2,130	170	2,300	2,190	330	2,520	2,260	330	2,590	2,310	500	2,810
Maximum Month	2,340	22.3	2,360	190	2,550	2,430	190	2,620	2,510	380	2,890	2,580	380	2,960	2,640	570	3,210
Maximum Day	2,720	8.8	2,740	230	2,970	2,830	230	3,060	2,910	440	3,350	2,990	440	3,430	3,070	660	3,730
TP, lb-P/day																	
Average Annual	263	5.09	266	21	287	273	21	294	281	42	323	289	42	331	297	64	361
Maximum Month	299	2.85	301	24	325	311	24	335	320	48	368	330	48	378	337	73	410
Maximum Day	324	1.04	327	26	353	337	26	363	347	52	399	356	52	408	366	79	445
*Based on second largest maximum month flow recorded in August 2015.																	
**Based on largest maximum day flow recorded on May 31, 2008.																	

This page intentionally left blank.

Table 7: Effluent Data (January 1, 2015 – December 31, 2017)

	Load, lb/day	Concentration, mg/L
Flow, MGD		
Average Annual	6.19	-
Maximum Month	8.65	-
Maximum Day	18.4	-
cBOD₅, lb/day		
Average Annual	223	4.0
Maximum Month	396	7.0
Maximum Day	1,400	15.8
TSS, lb/day		
Average Annual	306	5.9
Maximum Month	698	13.0
Maximum Day	2,900	26.7
Ammonia, lb-N/d		
Average Annual	6.76	0.13
Maximum Month	16.9	0.27
Maximum Day	116	1.07
TN, lb-N/d		
Average Annual	1,250	23.0
Maximum Month	1,510	31.3
Maximum Day	1,970	38.7
TP, lb-P/d		
Average Annual	199	3.8
Maximum Month	249	5.3
Maximum Day	300	5.9

Based on Monthly Operating Report Data

3.2 Nutrient Reduction Capability

The existing Ames WPCF achieves nutrient reductions relative to 2013 Iowa Nutrient Reduction Strategy targets as summarized in Table 8. As indicated in the table, the Ames WPCF is achieving an annual average total nitrogen (TN) reduction of 42.1 percent relative to the strategy target of 66 percent and an average annual total phosphorus (TP) reduction of 25.3 percent relative to the strategy target of 75 percent.

Table 8: WPCF Nutrient Reduction (January 1, 2015 – December 31, 2017)

Parameter	Total Nitrogen		Total Phosphorus	
	Value	Unit	Value	Unit
Average Influent Load*	2,050	lb-N/day	263	lb-P/day
Average Effluent Load*	1,187	lb-N/day	196	lb-P/day
Average Influent Concentration	39.7	mg-N/L	5.09	mg-P/L
Average Effluent Concentration	23.0	mg-N/L	3.80	mg-P/L
Current Nutrient Removal	42.1	%	25.3	%
NRS** Target Reduction	66	%	75	%
Average Effluent Concentration Target	13.5	mg-N/L	1.27	mg-P/L
Average Effluent Load Target	697	lb-N/day	65.6	lb-P/day

*Loading based on average annual flow of 6.34 MGD

**NRS = Iowa Nutrient Reduction Strategy

4 Nutrient Baseline

Table 9 provides estimated total watershed loadings for the South Skunk River Watershed. Nonpoint source loadings were based on the United States Geological Survey (USGS) SPATIally Referenced Regressions On Watershed Attributes (SPARROW). Point source loadings were estimated from typical pollutant concentrations and average dry weather flows. Figure 4 and Figure 5 present the distributions of the SPARROW nonpoint source loadings.

Table 9: Nutrient Loadings in the South Skunk River Watershed

Location		Total Phosphorus, lb/year	Total Nitrogen, lb/year
Total Skunk River Watershed	Nonpoint	769,000	19,115,000
	Point	136,000	775,000
	Total	905,000	19,890,000
Skunk River Watershed Upstream of the Ames WPCF	Nonpoint	276,000	8,950,000
	Point*	80,000	491,000
	Total	356,000	9,441,000

*Inclusive of the Ames WPCF

On an average annual basis, agricultural contributions of nutrients represent the largest fraction of the TP and TN loading in the watershed. Depending on the location within the South Skunk River Watershed, SPARROW results suggest that farm fertilizer and manure collectively represent approximately 72 percent to 76 percent of TP loadings and 66 percent to 68 percent of TN loadings. SPARROW results suggest that urban stormwater loadings represent approximately 14 percent to 16 percent of TP loadings and 4 percent to 5 percent of TN loadings within the watershed.

In contrast, Table 10 presents the estimated annual nutrient loadings from the Ames WPCF. Approximately 71,540 pounds per year of TP (approximately 8 percent of the total watershed load and approximately 20 percent of the upstream watershed load) and 433,255 pounds per year of TN (approximately 2 percent of the total watershed load and 5 percent of the upstream watershed load).

Table 10: Ames WPCF Nutrient Loadings in the South Skunk River Watershed

	Total Phosphorus	Total Nitrogen
Average Effluent Concentration (2015-2017), mg/L	3.80	23.0
Average Load*, lb/day	196	1,187
Average Load*, lb/year	71,540	433,255

*Loading based on average annual flow of 6.34 MGD

The South Skunk River Watershed includes 23 municipal and semi-public wastewater treatment facilities. Total point source loadings within the South Skunk River Watershed are estimated at 136,000 pounds per year of TP and 775,000 pounds per year of TN. Based on available information, the Ames WPCF represents the largest point source discharge within the watershed at approximately 53 percent of the total TP point source load and 56 percent of the total TN point source load.

This page intentionally left blank.

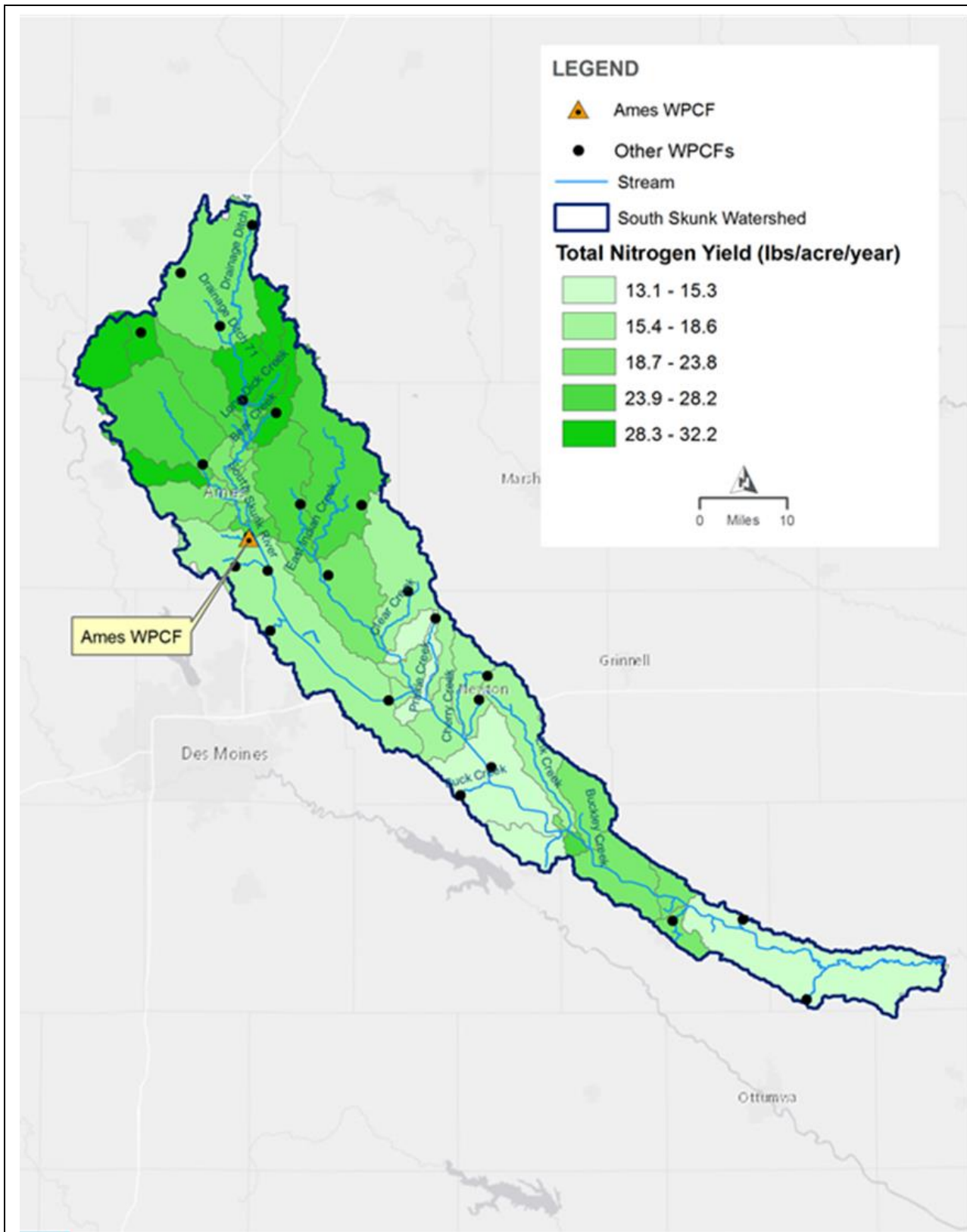

Figure 4: SPARROW Model Total Nitrogen Nonpoint Source by Area

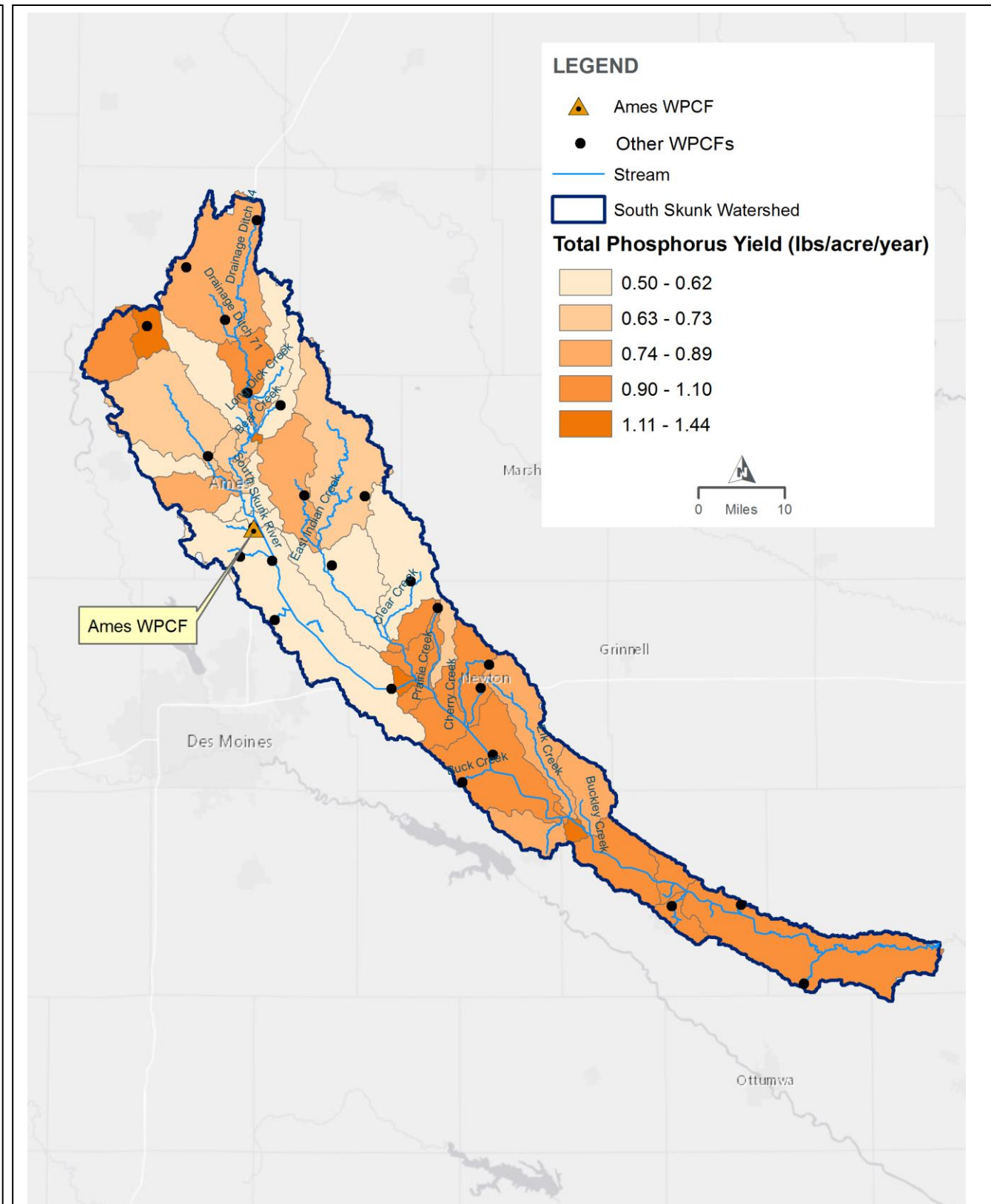

Figure 5: SPARROW Model Total Phosphorus Nonpoint Source by Area

This page intentionally left blank.

The 2013 Iowa Nutrient Reduction Strategy targets 66 percent of TN and 75 percent of TP equivalent annual reductions in raw wastewater point source discharges. Based on current loadings, Ames WPCF targeted reductions are as follows.

- Approximately 72,000 pounds per year of TP, of which the Ames WPCF is currently removing approximately 24,500 pounds per year of TP.
- Approximately 493,800 pounds per year of TN, of which the Ames WPCF is currently removing approximately 315,000 pounds per year of TN.

Relative to upstream nonpoint source loads, the Ames WPCF targeted reductions suggest that opportunities exist for addressing nutrient reduction targets through implementation of BMPs upstream of the Ames WPCF, particularly for TN reductions.

5 Ames WPCF Nutrient Reduction

Several approaches have been considered for Ames WPCF nutrient reduction, including source reduction, solids recycle stream management, operation changes, and alternative technology implementation. Each is discussed in the following.

5.1 Ames WPCF Source Reduction

Figure 6 shows that industry and university sources contribute just under 20 percent of the phosphorus and just over 20 percent of the nitrogen influent loadings at the Ames WPCF. The City’s water treatment plant contributes an estimated 4 percent of the phosphorus loading at the Ames WPCF. Residential and commercial sources account for the majority of influent loadings, nearly 80 percent for both phosphorus and nitrogen.

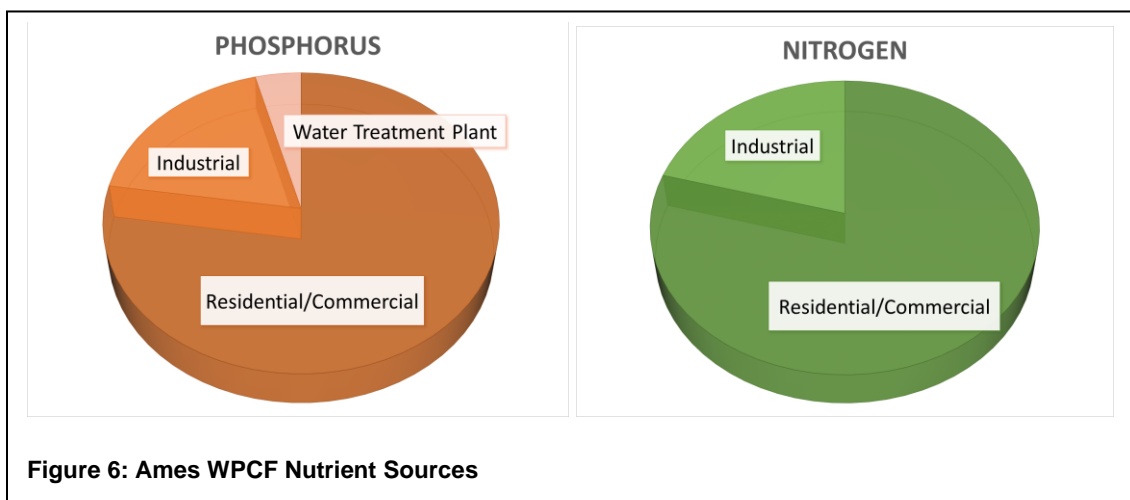

Additional data should be obtained and discussions should occur with the most significant industry and university sources, but it appears unlikely that such reductions could be a particularly significant part of the City’s nutrient reduction strategy. There is no single large contributor of either phosphorus or nitrogen.

Similarly, water treatment plant phosphorus discharges are not likely a significant part of the City’s nutrient reduction strategy; they are a relatively insignificant contributor to Ames WPCF influent phosphorus loadings and are critical to the production of a stable noncorrosive potable water supply to the City.

Figure 7 identifies various sources of phosphorus in residential and commercial wastewater based on research by Sean Comber et al. in 2012.

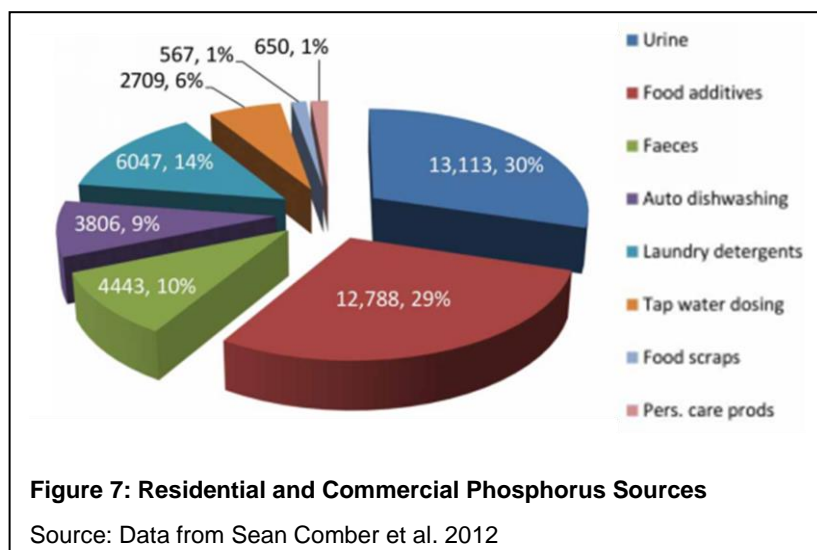

As reflected in the data (Figure 7), urine, food additives, and faeces (sp) account for nearly 70 percent of the phosphorus, with dishwashing and laundry detergents accounting for approximately 23 percent.

Phosphorus contributions from detergents reflect a downward trend that began with restrictions on phosphate in laundry detergent in the early 1970s, continued with a nationwide voluntary ban in 1994, and multiple states following up with bans on phosphate use in automatic dishwasher detergent in 2010. Additional investigations specific to the City of Ames could be conducted, but it appears unlikely that residential and commercial wastewater source reductions could be a particularly significant part of the City's nutrient reduction strategy.

5.2 Solids Recycle Management

Currently, Ames WPCF generated solids are anaerobically digested and land applied on adjacent property as liquid biosolids. Nutrients associated with the land applied biosolids are effectively removed and not recycled to the liquid treatment train. As waste solids are discharged to anaerobic digestion, the primary digester overflows to the secondary digester, which overflows to either the sludge lagoon or to the first stage trickling filter wetwell. Sludge lagoon supernatant is returned to the raw wastewater pump station wetwell.

The nutrient loading on the secondary treatment process at the Ames WPCF is increased by both the sludge lagoon supernatant return to the raw wastewater wetwell and the digester overflow to the first stage trickling filter wetwell. It varies significantly day to day and seasonally, but an estimated 10,000 gallons per day of supernatant or decant returned to the Ames WPCF on an annual average basis.

The amount of phosphorus in the digester supernatant and lagoon decant is highly dependent on metals precipitation, struvite formation, and pH in the digester and precipitation, temperature related turnover, and solids dredging activities in the lagoon. On average, phosphorus concentration is estimated to be as high as 400 to 500 milligrams per liter (mg/L), but more likely is lower in field conditions. This translates to a resulting solids recycle loading estimated to be 33 pounds per day of phosphorus on average, the equivalent of 0.66 mg/L of effluent TP.

Likewise, the sludge lagoon decant and digester supernatant streams also include high amounts of ammonia. On average, the ammonia concentration is estimated to be up to 1,300 mg/L. At this concentration, these streams could be returning up to 108 pounds per day of ammonia on an average, the equivalent of 2.2 mg/L in the liquid stream.

Solids recycle treatment to remove these nutrient loads from the Ames WPCF would not be sufficient by itself to achieve nutrient reduction targets. However, treatment or mitigation of these solids recycle streams could benefit the overall nutrient removal performance of the Ames WPCF. Given limited available data, sampling and testing would need to be performed on the decant and supernatant to confirm actual concentrations of TP and ammonia and the benefit of treatment.

Without nutrient limits, solids recycle loadings are benign with regard to permit compliance; this changes with nutrient limits in place. Figure 8 shows the primary effluent and Stage 1 trickling filter TSS. The periodic spikes in TSS are likely due to the digester decant or lagoon overflow returned to the raw wastewater and trickling filter pump station wet wells. With elevated solids loadings come elevated TP loadings.

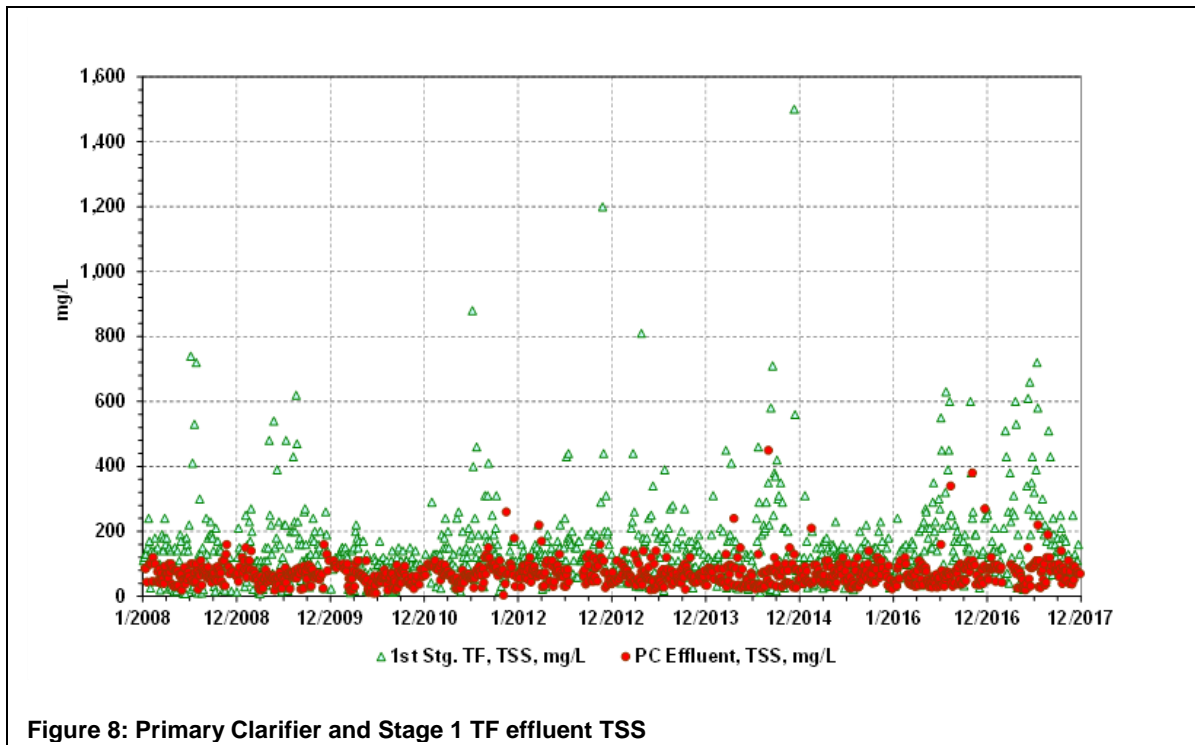

Figure 8: Primary Clarifier and Stage 1 TF effluent TSS

Table 11 identifies a number of options that could be considered for improvement recycle management.

Table 11: Improvement Recycle Management Options

Option	Description
1. Digested sludge dewatering	Dewater enough digested sludge with small machine to eliminate lagoon overflows.
2. Mechanical thickening	By improving thickening upstream of the digester, less decanting will be required to achieve the same storage capacity.
3. Blending digester decant with waste activated sludge (WAS)	If mechanical thickening of WAS is implemented, the digester decant can be blended with the WAS upstream of thickening, which would retain most of the solids.
4. Eliminate digester decanting	Solids will thicken in the sludge lagoon and its overflow is much lower in TSS (most of the time).
5. Lagoon overflow control and isolation	The normal sludge lagoon operating water level would be lowered by 1 foot, the overflow would be monitored for TSS, and lagoon decanting would be discontinued at TSS levels above a setpoint.

Options 1 through 3 require implementation of solids thickening and/or dewatering and a significant change from the current liquid biosolids land application practice. Options 4 and 5 depend on sufficient liquid sludge storage, either in the digesters or in the sludge lagoons. Available sludge storage volume is already a limiting factor at the existing Ames WPCF with respect to seasonal limits on biosolids land application. Coupled with the limited nutrient reduction potential, improved solids recycle management is not a viable approach to achieve

the targeted reductions on its own. However, one or more of the solids recycle management options should be considered in conjunction with implementation of alternative technology to achieve targeted nutrient reductions.

5.3 Ames WPCF Operation Changes

The existing trickling filter solids contact treatment process is not adaptable operationally to increased nutrient reduction. It is not configured to provide the anaerobic and anoxic environments and associated carbon source for phosphorus and nitrogen removal. Nutrient removal optimization opportunities focus on ways to integrate biological phosphorus removal by creating anaerobic conditions in the RAS reaeration tanks and providing a carbon source. To achieve anaerobic conditions, denitrification of the RAS is necessary and, coincidentally, would achieve some nitrogen removal with phosphorus removal. The carbon could be supplied either by diversion of some primary effluent around the trickling filters or by providing filtrate from primary sludge thickening.

Currently WAS is co-thickened with primary sludge in the primary clarifiers and pumped directly to the anaerobic digesters. To operate biological phosphorus removal, WAS must be handled separate from primary sludge. Otherwise, co-thickening in the primary clarifier would most certainly result in stored phosphorus release to the liquid stream, because any extended contact between the WAS and raw influent results in stored phosphorus release to the degree that volatile fatty acids would be present. The phosphorus release is quick, with only 15 to 30 minutes contact time required during which the raw influent volatile fatty acids are consumed by non-beneficial phosphorus release and are no longer available as a carbon source for biological phosphorus removal in the RAS tanks. Therefore, all optimization options need to have dedicated WAS thickening.

Six optimization options were identified for the Ames WPCF to target biological phosphorus removal and produce lower effluent phosphorus concentrations. All six options include various combinations of flow routing, repurposing of facilities, separate solids thickening, and modified operations noted in Table 12 to create an anaerobic zone with sufficient carbon source for phosphorus uptake. Specifics for each of the optimization options are presented in Attachment A.

Table 12: Ames WPCF Optimization

Number	Ames WPCF Optimization
1	Create anaerobic zone for phosphorus uptake using a) part or all of existing RAS reaeration tanks, b) one primary clarifier, and/or c) one secondary clarifier
2	Increase carbon loading on anaerobic zone by a) diverting a portion of primary effluent around the trickling filters and b) installing dedicated sludge thickening and diverting thickening liquid stream

The resulting model predicted effluent quality for each is presented in Table 13. The construction cost, TP reduction, and comparative cost for each optimization option is reflected in Table 14. The construction costs are estimates for comparative purposes only that do not include engineering. The identified percent TP reductions represent the incremental annual average reduction beyond the reduction currently achieved at the Ames WPCF as reported previously in Table 8. The reported pounds TP reduction reflects a 20-year period at an average flow rate of 7.0 MGD.

Table 13: Nutrient Reduction Option Effluent Summary

Option	Flow (MGD)	Model* Predicted Effluent Concentrations, mg/l*				
		PO4-P	TP	NH4-N	TN	TSS
Existing	6.0	3.2	3.3	0.1	24.0	11
1	7.0	1.2	1.4	2.7	27.5	7
2	7.0	1.0	1.2	2.8	27.4	6
3	7.0	1.1	1.5	10.0	27.9	9
4	7.0	1.0	1.5	10.0	28.0	9
5	7.0	1.4	1.8	2.5	24.5	9
6	7.0	5.6	2.7	9.9	28.0	9

*GPS-X™ Wastewater Modeling Software

Table 14: Nutrient Reduction Option Comparative Costs

Option	Construction Cost	Effluent TP	% TP Red.	TP Red	Relative Cost
		mg/L	%	lb	\$/lb TP
1	\$4,850,000	1.4	58%	809,800	\$6
2	\$8,325,000	1.2	64%	895,000	\$9
3	\$4,850,000	1.5	55%	767,200	\$6
4	\$8,325,000	1.5	55%	767,200	\$11
5	\$10,575,000	1.8	45%	639,300	\$17
6	\$9,325,000	2.7	18%	255,800	\$36
7	\$9,450,000	2.6	21%	298,400	\$32

Nitrogen removal performance will be similar to existing Ames WPCF nitrogen removal performance.

Five of the six optimization options achieved the targeted phosphorus reduction at reasonable costs ranging from \$6 to \$17 per pound of phosphorus removal. However, none of the options provided any additional nitrogen reduction. Additionally, construction costs ranged from \$4.9 million to \$10.6 million, the optimization concepts would require pilot testing prior to implementation, and all optimization options reflected continued dependency on trickling filter technology that needs to be replaced to achieve biological nitrogen and phosphorus removal. Components of the optimization options should be incorporated into the alternative treatment technology options identified in the following to the extent that they are compatible.

5.4 Ames WPCF Treatment Technologies

Treatment technologies to achieve biological nutrient removal at the Ames WPCF were initially identified and screened, then further developed and evaluated before selection of the preferred technology. Both steps are described in the following.

5.4.1 Alternatives Identification and Screening

Five biological nutrient removal technologies are identified as potentially applicable for implementation at the Ames WPCF. All five alternatives shown in Table 15 represent a conversion from the current trickling filter solids contact technology and are capable of achieving the targeted 2013 Iowa Nutrient Reduction Strategy requirements.

Table 15: Alternative Technology

Number	Alternative Technology
1	2012 Baseline Alternative – Simultaneous Nitrification and Denitrification
2	Alternative 1 – Carbonaceous Activated Sludge BNR with RAS Fermentation
3	Alternative 2 – Integrated Fixed Film Activated Sludge BNR with RAS Fermentation
4	Alternative 3 – Granular Activated Sludge
5	Alternative 4 – Membrane Aerated Bioreactor

Simultaneous nitrification and denitrification is the baseline alternative given that it was the alternative with the lowest present worth cost at the time of the *2012 Long Range Facility Plan*. That Plan was developed in anticipation of, but prior to, the 2013 Iowa Nutrient Reduction Strategy. The Plan contemplated three potential levels of nutrient reduction: levels achieved through biological nutrient removal; lower levels achieved through enhanced nutrient reduction; and the lowest levels achievable within the limits of technology.

The other four alternatives identified in Table 15 reflect advancements in nutrient reduction technology since 2012 and specifically target biological nutrient removal consistent with the 2013 Iowa Nutrient Reduction Strategy. Given site limitations, alternatives with a smaller footprint are preferable from a constructability perspective. The degree to which each alternative can be implemented in phases is important given the need for phase implementation to manage rate impacts on customers. Likewise, the ability to accommodate peak wet weather flows and consistency with current solids handling facilities are important to consider when selecting technology.

Several other emerging technologies were identified as potentially applicable in the future, but were not selected at the screening level for inclusion in the current planning effort. Those technologies include:

- Use of lime solids from the City's water treatment plant for chemical phosphorus removal at the Ames WPCF.
- Algae treatment for effluent or solids recycle nutrient reduction.
- Microvi MNETM process for targeted removal of soluble contaminants including nitrification and denitrification.
- Mainstream or sidestream annamox for nitrogen removal.
- InDence hydro cyclones for increasing the density of activated sludge flocs for enhanced activated sludge performance.

Figure 9 provides preliminary site layouts for each of the alternative technologies. Comparative costs are presented in Table 16, and nonmonetary criteria comparisons are presented in Table 17.

Table 16: Comparative Costs (\$2018)

Parameter	Unit	SNDN	CAS-BNR	IFAS BNR	GRAS	MABR
Capital Cost	mil \$	20.9***	20.0	26.6	22.2	30.4
Annual Operation Cost	mil \$/yr	0.95	1.12	1.33	1.03	1.32
Present Worth Operation Cost	mil \$	14.2	16.6	19.8	15.3	19.6
Total Present Worth*	mil \$	35.1	36.7	46.4	37.6	50.0
Cost per Nitrogen Removed	\$/lb	2.55	2.67	3.38	2.74	3.64
Cost per Phosphorus Removed	\$/lb	17.96	18.78	23.74	19.24	25.58
Rank (1 to 5 Best to Worst)		1	2	4	3	5

*Present worth costs reflect a 3 percent interest rate over 20 years

**Capital Costs include construction, contingency, engineering, and administration

***Updated from 2012 using the approach and tools as other alternatives

Table 16 identifies the Baseline SNDN, CAS BNR, and GRAS alternatives are the lowest total present worth cost alternatives in that order, but have comparable capital, operations and maintenance, and present worth costs. Based on estimating accuracy, all three should be considered equal. Notably, there was a clear break in costs with integrated fixed film activated sludge (IFAS) BNR and membrane aerated bioreactor (MABR) being significantly higher than the other three alternatives.

Table 16 also identifies nitrogen reduction costs an estimated \$2.50 to \$2.75 per pound removed and phosphorus reduction costs an estimated \$18.0 to \$19.25 per pound removed.

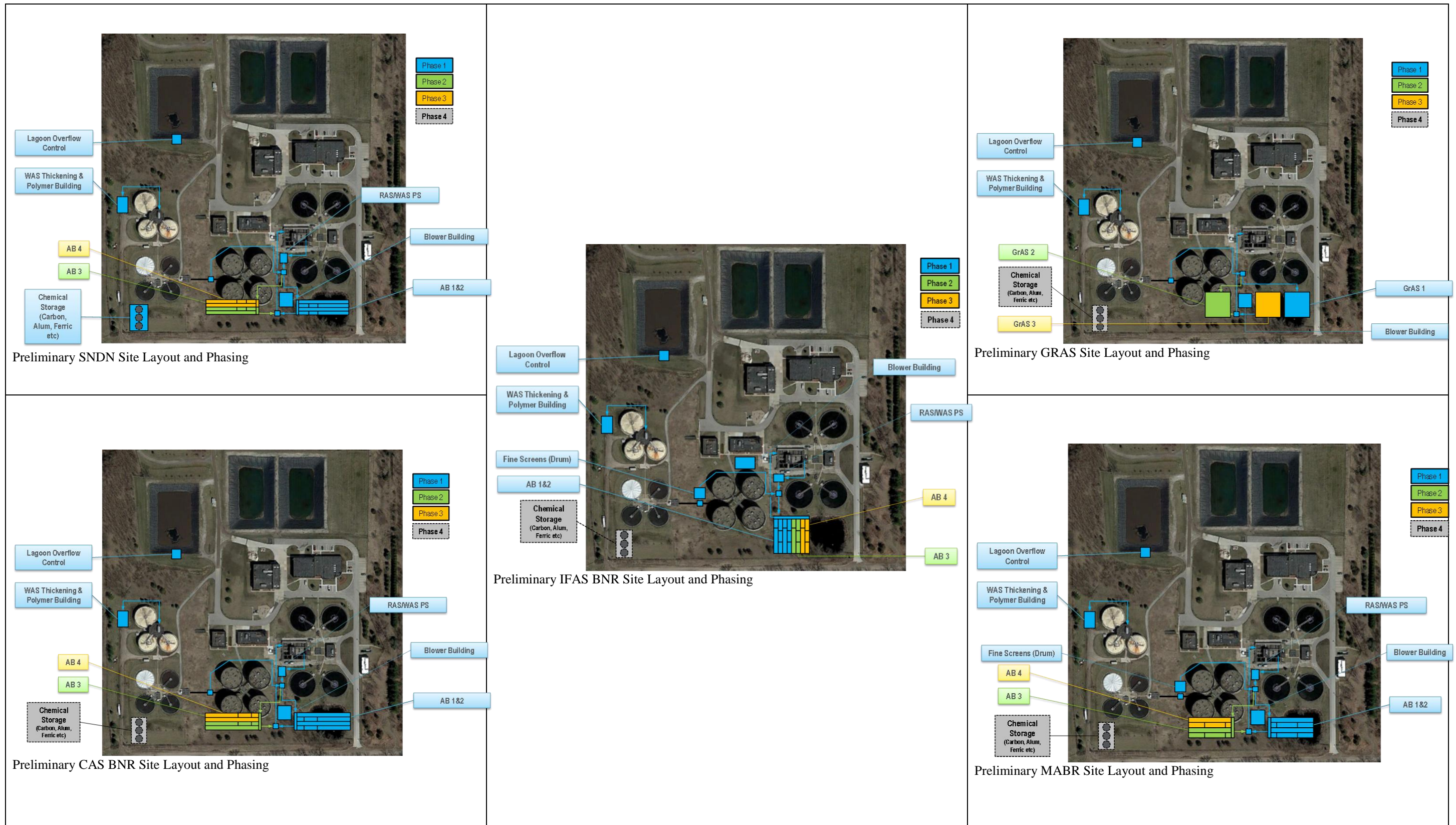

Figure 9: Ames WPCF Alternative Site Layouts

This page intentionally left blank.

Table 17 indicates that the Baseline SNDN, CAS BNR, and GRAS alternatives scored most favorably with respect to both nonmonetary performance and acceptance criteria. Again, with a clear break in favorability with IFAS BNR and MABR being less favorable.

Table 17: Nonmonetary Criteria Comparison*

	Performance Criteria	SNDN	CAS-BNR	IFAS BNR	GRAS	MABR
1	Reliability	4	5	3	4	2
2	Amenable to wet weather flow	4	4	4	3	3
3	Solids handling	4	4	4	4	4
4	Effectiveness-Consistently meet permit	4	5	3	4	3
5	Adaptability to more stringent nutrient standards	3	3	2	3	2
6	Constructability	2	3	4	5	4
	TOTAL	21	24	20	23	18
	Rank (1 to 5 Best to Worst)	3	1	4	2	5

	Acceptance Criteria	SNDN	CAS-BNR	IFAS BNR	GRAS	MABR
1	Consistency with current operations	3	3	2	1	1
2	Safety	5	5	5	5	5
3	Positive public opinion	4	4	4	5	5
4	Operational requirements	4	4	3	4	3
5	Maintenance requirements	4	4	3	4	3
6	Operations during construction	3	3	5	5	3
	Reliability	21	24	20	23	18
	TOTAL	21	24	20	23	18
	Rank (1 to 5 Best to Worst)	3	1	4	2	5

*Each alternative is rated for each criteria on a scale of 1 (worst) to 5 (best)

Based on both comparative costs and nonmonetary criteria considerations, Baseline SNDN, CAS BNR, and GRAS were selected for further development and evaluation. IFAS media and MABR membranes can be subsequently retrofitted into any of the other three alternatives at a future date if the City were to experience a significant increase in organic loading, causing the footprint to become a significant consideration at that time.

5.4.2 Key Findings and Ames WPCF Strategy

Key findings with respect to on-site Ames WPCF nutrient reductions are as follows, with the first three being most significant.

1. Facilities incorporating alternative treatment technology would be required at Ames WPCF to achieve 2013 Iowa Nutrient Reduction Strategy required reductions.
2. The existing trickling filters are not part of the long-term solution at Ames WPCF due to process limitations and condition.
3. The existing trickling filters should be used as long as condition allows, minimizing customer rate impacts.
4. Influent wastewater source reductions alone cannot achieve the required reductions.
5. Ames WPCF solids recycle management alone cannot achieve the required reductions.
6. Ames WPCF optimization alone cannot achieve the required reductions.

Table 18 identifies the resulting on-site Ames WPCF nutrient reductions strategies.

Table 18: On-site Ames WPCF Nutrient Reduction Strategies

Number	On-site Ames WPCF Nutrient Reduction Strategy
1	Convert from trickling filters to an alternative technology that provides additional capacity as well as nutrient removal capability that achieves the goals of the 2013 Iowa Nutrient Reduction Strategy
2	Minimize costs and associated customer rate impacts through phased implementation that continues to use existing trickling filter capacity as long as condition allows
3	Implement the alternative technology in phases that allows performance and capacity to be demonstrated and design criteria to be refined
4	Incorporate existing trickling filter and solids contact optimization options to the extent they are affordable and consistent with the alternative technology selected
5	Consider bench and pilot testing of lime sludge addition as alternative solution for phosphorus removal and/or chemical feed for phosphorus removal as interim solution

5.4.3 Alternatives Development and Evaluation

Three alternatives were further developed and evaluated with respect to process performance, solids considerations, wet weather issues, capital costs, and operations and maintenance costs. The following phasing goals provided the basis for further evaluation and development of the three alternatives:

- Meet existing permit limits, specifically ammonia limits, as the first priority throughout construction of each phase.
- Provide current and forecast future capacity while allowing the existing trickling filters to operate to failure over the next 5 to 10 years.
- Achieve Ames WPCF 2013 Iowa Nutrient Reduction Strategy targets progressively with full compliance by 2040.
- Minimize capital investment in Phase 1, deferring large capital investment due to rate and operations considerations.

- Minimize wasted new infrastructure through a phased implementation of the selected technology.
- Minimize complexity, impacts on operations, and solids handling.

Each alternative was developed based on the projected flow and loads previously presented in Table 6 for three phases:

- Phase 1: First 5 Years (2030 Flows and Loads)
 - Increase investment in urban watershed BMPs
 - Implement First Phase of alternative technology at Ames WPCF
- Phase 2: Second 5 Years (2035 Flows and Loads)
 - Continued investment in urban watershed BMPs
 - Implement Second Phase of alternative technology at Ames WPCF
- Phase 3: Last 10 Years (2040 Flows and Loads)
 - Implement Third Phase of alternative technology at Ames WPCF

Because of the configuration of the existing Ames WPCF, there are a number of complexities with respect to transitioning from the existing trickling filter solids contact process to an alternative technology for biological nutrient removal.

- Figure 10 shows that raw influent wastewater is mixed with first stage trickling filter effluent and then pumped to the primary clarifiers. Mixing produces a low BOD, high dissolved oxygen primary effluent that makes biological nutrient removal difficult. As long as the first stage trickling filters are in service, biological nutrient removal performance in the mainstream treatment process would be compromised because of low organic loading.
- For two of the three alternatives, Baseline SNDN and CAS BNR, the existing intermediate and final clarifiers need to remain in service, producing a common sludge for the existing trickling filter and parallel alternative technology trains. As long as the existing trickling filters are in service, the common sludge produced by the existing clarifiers precludes operation of alternative technology trains for biological nutrient removal.
- The third alternative, GRAS would not require continued operation of the intermediate and final clarifiers. This alternative could be configured to achieve biological nutrient removal simultaneously while still using the existing trickling filters.

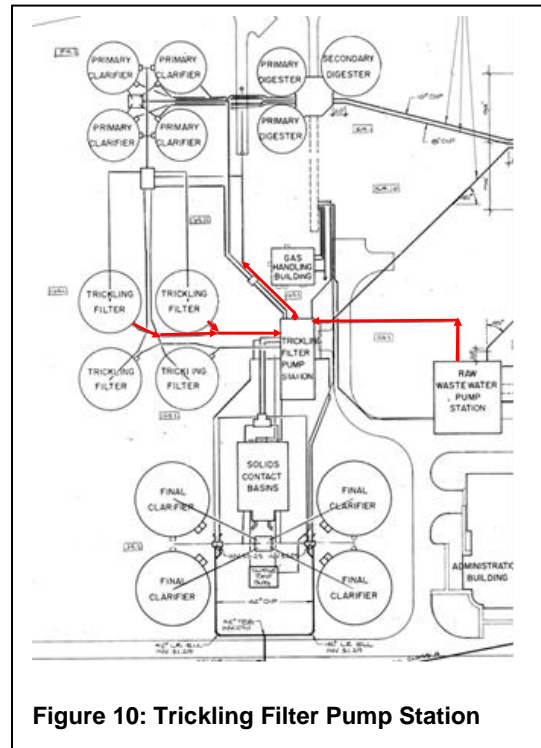

- As long as the existing return activated sludge screw pumps are in service, the hydraulic profile for the existing Ames WPCF precludes operation of the alternative technology at the desired water surface elevation. To capitalize on the remaining useful life of the existing pumps, the first phase of alternative technology would need to operate at a lower water surface elevation and reduced liquid depth as shown in Figure 11. Operating this way would adversely affect biological nutrient removal capability.
- Separate thickening of WAS would be required as the Ames WPCF transitions from trickling filter humus to WAS and to produce a recycle stream that serves as a carbon source for biological nutrient removal. Without the additional organic loading, biological nutrient removal would be compromised.

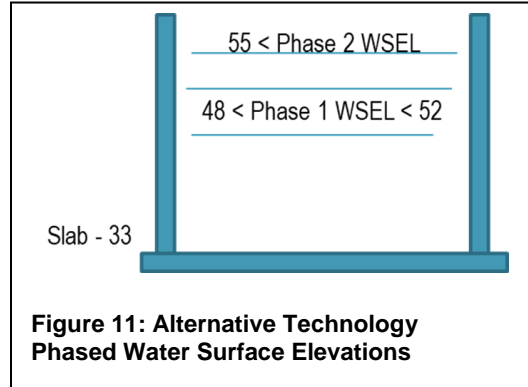

Refined site layout and process flow schematics for the three alternatives are presented in Figure 12; potential phasing is also shown in the figure.

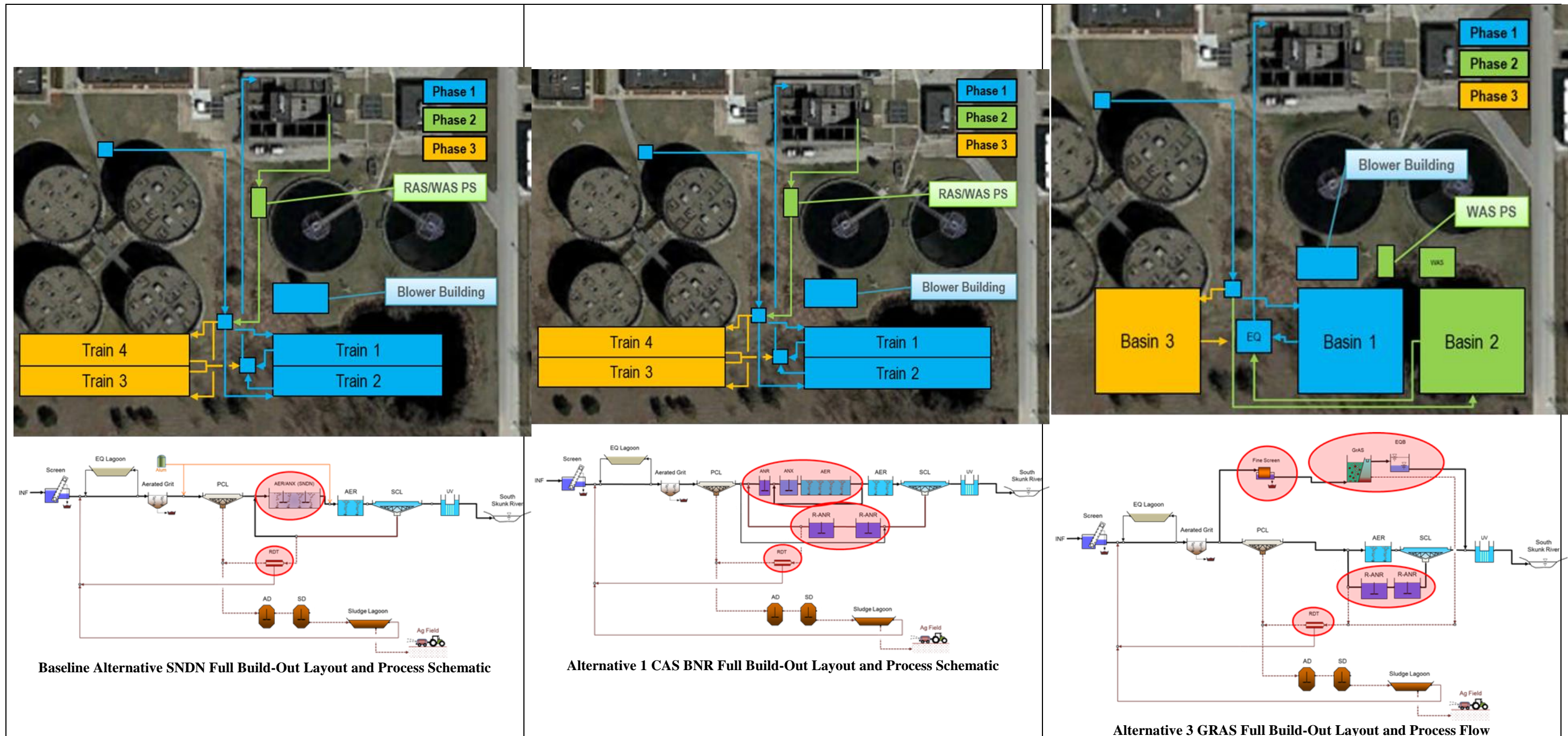

Figure 12: Ames WPCF Nutrient Reduction Alternatives

This page intentionally left blank.

Table 19 identifies the preliminary planning level estimated capital costs, operations and maintenance costs, and present worth costs for each alternative. All costs are expressed in 2018 dollars. Because cost depends on whether biological nutrient removal capabilities are incorporated into Phase 1 or incorporated into Phase 2 (which is similar the two other alternatives), two costs are presented for the GRAS alternative.

Table 19: Planning Level Estimated Costs (\$2018)

	SNDN	CAS BNR	GRAS without BNR in Phase 1	GRAS with BNR in Phase 1
Preliminary Planning Level Capital Costs				
Phase 1 (mil \$)	8.2	8.5	7.3	19.0
Phase 2 (mil \$)	11.2	10.0	18.6	7.0
Phase 3 (mil \$)	8.6	7.8	6.2	6.1
Total	28.0	26.3	32.1	32.1
Total Rating	2	1	3	3
Preliminary Planning Level Operations and Maintenance Costs				
Phase 1 (mil \$)	0.28	0.31	0.30	0.34
Phase 2 (mil \$)	0.70	0.45	0.42	0.41
Phase 3 (mil \$)	0.70	0.45	0.42	0.41
Total	1.68	1.21	1.14	1.16
Total Rating	4	3	1	2
Preliminary Planning Level Present Worth Costs				
Phase 1 (mil \$)	12.3	13.1	11.7	24.0
Phase 2 (mil \$)	21.7	16.7	24.9	13.1
Phase 3 (mil \$)	19.1	14.5	12.5	12.2
Total	53.1	44.3	49.1	49.3
Total Rating	4	1	2	3

Capital costs include contingency, engineering, and administrative costs. Operations and maintenance costs include chemical, electrical, material, labor, and solids handling costs. Labor costs were based on the hours required for operations and maintenance of the proposed capital improvements for each alternative and do not include operation of existing facilities. Labor costs were based on a rate of \$35 per hour. Solids handling and disposal costs include new WAS thickeners for activated sludge based options and continued disposal using land application. The total present worth summarizing capital costs and operations and maintenance costs for a 20-year period assuming an interest rate of 3 percent were developed for each alternative.

The CAS BNR alternative has the lowest capital cost and total present value cost, but all three alternatives are similar in life-cycle costs and nonmonetary value.

- Baseline SNDN
- Alternative 1 CAS BNR
- Alternative 3 GRAS

Final selection of a specific technology should be deferred until design of Phase 1 begins. Deferred selection allows City and Ames WPC staff to become familiar with each technology by providing time to make site visits to other operating facilities. As an emerging technology, this allows the GRAS technology to continue to be developed, potentially yielding additional benefits and cost reductions that are unknown and unrealized at this time.

6 Watershed Nutrient Reductions

Off-site watershed nutrient reductions could be part of an integrated strategy for the Skunk River Watershed and Ames WPCF to potentially supplement or offset current or future WPCF nutrient reduction requirements. Nutrient offset is a form of water quality trading whereby pollutant control requirements for point sources can be met through off-site watershed reductions. The Nutrient Reduction Exchange program under development in Iowa will provide a mechanism to capture and document watershed nutrient reductions.

6.1.1 Potential Practices

Potential agricultural and urban stormwater BMPs targeted at nutrient reduction are presented in the following. These BMPs could be synergistic with flood mitigation, wetland mitigation banking, source water protection, water quality, and other ancillary benefits.

Agricultural BMPs. Figure 13 identifies several agricultural BMPs. Table 20 presents the associated performance and cost. Most are well established and shown to not only be effective at reducing nutrient loadings, but to have other ancillary benefits including reduced soil erosion and improved habitat. Performance, as measured by nutrient reduction rates and costs, are highly variable and site specific for individual BMPs. Table 20 reflects assumed performance and cost numbers estimated from literature, 2013 Iowa Nutrient Reduction Strategy, and the Natural Resources Conservation Service (NRCS) Environmental Quality Incentives Program (EQIP) practice costs. Actual agricultural BMP performance and costs could vary significantly.

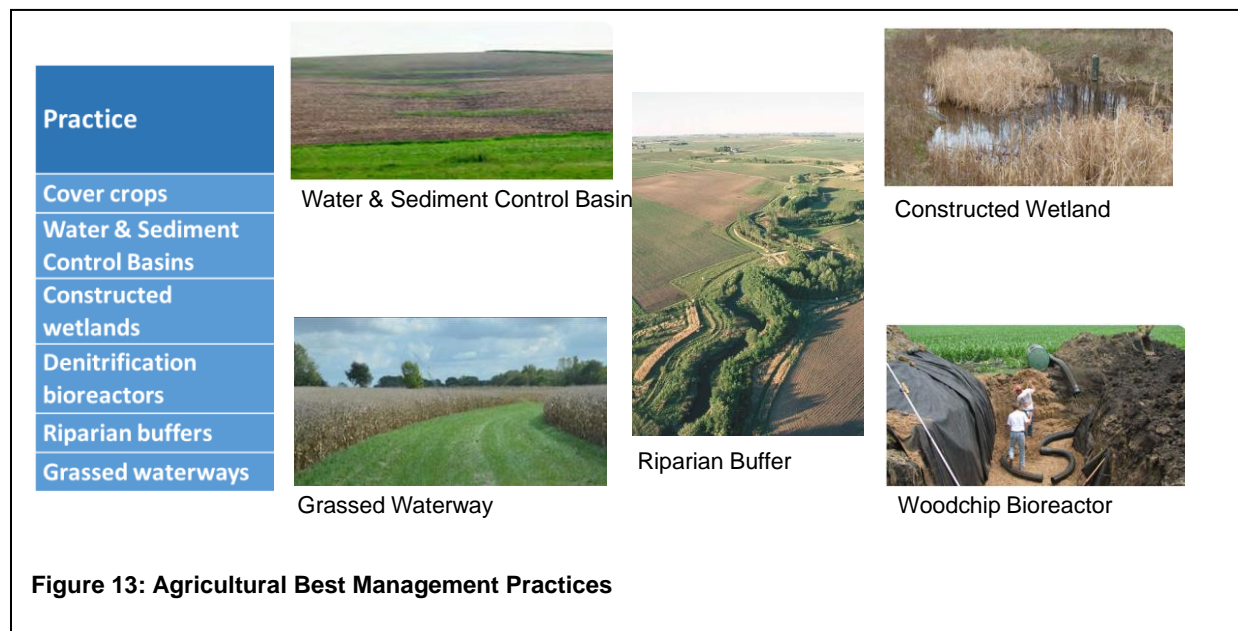

Analysis suggests that constructed wetlands appear to be the best value for nitrogen and phosphorus, denitrifying bioreactors appear to offer value with respect to nitrogen, and water and sediment control basins appear to offer value with respect to phosphorus.

The nutrient reduction targets for the Ames WPCF are 47,450 pounds per year for phosphorus and 179,200 pounds per year for nitrogen. In comparison, Table 21 identifies the availability of potential nutrient reduction credits for individual BMPs to offset Ames WPCF requirements. The estimated reduction credits reflect the results of an Agricultural Conservation Planning Framework (ACPF) analysis. ACPF is a toolset for identifying and optimizing the placement of BMPs on the landscape.

Based on ACPF findings, there are sufficient nitrogen credits upstream of the Ames WPCF to address its reduction targets for most individual BMPs. From a credit supply and cost perspective, the BMP of using constructed wetlands appears to be the most promising of all the BMPs. While there appears to be sufficient nitrogen credits upstream, the analysis suggests that offsetting 100 percent of Ames WPCF phosphorus removal targets with upstream reduction credits would be impractical given that doing so would require nearly 100 percent implementation of potential upstream BMP sites.

Iowa State University is researching an additional practice that could make cover crops significantly more attractive. That concept, perennial groundcover in the presence of row crops (see Figure 14), appears to offer multiple benefits in terms of both continued crop productivity, improved water quality, and reduced cost. However, cost information and nutrient removal rates for this practice were not readily available for analysis.

Table 20: Performance and Cost of Agricultural Best Management Practices

Practice	% Reduction		Cost of TN Reduction, \$/lb	Cost of TP Reduction, \$/lb
	TN	TP		
Cover crops	31%	29%	\$6.00	\$210
Water and sediment control basins	0%	80%	--	\$29
Constructed wetlands	52%	58%	\$1.20	\$35
Denitrification bioreactors	43%	0%	\$1.50	--
Riparian buffers	7%	18%	\$5.50	\$70
Grassed waterways	7%	18%	\$33	\$410

Table 21: Potential Applicability of Agricultural Best Management Practices

Practice	Treatment Area, ac	Potential Credits (lbs/yr)	
		TN	TP
Cover crops	304,133	2,262,768	65,280
Water & Sediment Control Basins	7,768	0	4,896
Constructed wetlands	176,507	2,202,792	75,752
Denitrification bioreactors	57,870	597,176	0
Riparian buffers	235,100	394,944	31,280
Grassed waterways	65,663	110,296	8,704

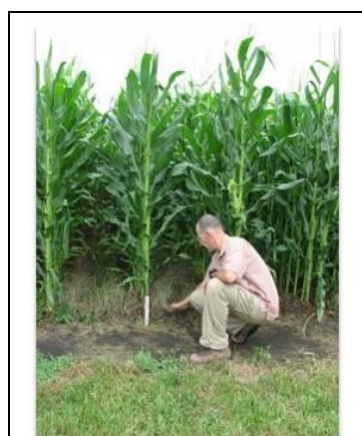

Figure 14: Perennial Cover Crop

Urban Stormwater BMPs. The City has a history of incorporating urban stormwater BMPs into public works projects, notably the following:

- City Hall Parking Lot Reconstruction
- Stormwater Erosion Control Project – South Skunk River from Carr Park to Homewood Golf Course
- Bioretention Cells on 24th Street with Street Rehabilitation Project
- Riffle Pools and Streambank Stabilization with Squaw Creek Water Main Stabilization at Lincoln Way
- Phosphorus Free Fertilizer on Parks
- Water Quality Treatment of Stormwater Runoff through City's Current Post-Construction Ordinance

These urban stormwater BMPs can achieve off-site watershed nutrient reduction and can provide other ancillary benefits. As standalone projects, these urban stormwater BMPs are significantly more expensive, ranging from several hundred to several thousand dollars per pound for both nitrogen and phosphorus.

6.1.2 Key Findings and Strategy

Ancillary benefits of agricultural BMPs and urban stormwater BMPs include potential flood mitigation, other water quality improvements such as reduced sedimentation, wetland mitigation, additional wildlife habitat, water source protection, and recreational opportunities. Potential synergies provide additional incentive for the City to pursue off-site watershed nutrient reductions.

Use of off-site watershed nutrient reductions as potential offsets to Ames WPCF required reductions is in the formative stage in Iowa. As currently envisioned, offsets are more a means to avoid more stringent Ames WPCF requirements in the future than to reduce the initial Ames WPCF requirements. In any case, there are a number of regulatory issues to be addressed before offsets may be directly applied toward meeting permit requirements. These include, but are not limited to, defining baseline conditions for generating nutrient credits, determining the watershed trading area and trading ratios, and addressing issues of liability, monitoring, and enforcement.

Key findings with respect to off-site watershed nutrient reductions are as follows, with the first being most significant.

1. It is not practical to offset the need for Ames WPCF nutrient reductions entirely with watershed nutrient reductions.
2. Land requirements for offsetting watershed nutrient reductions are surprisingly large.
3. There is no guarantee that watershed nutrient reductions are acceptable offsets to Ames WPCF reductions short term, but an exchange program is under development to enable watershed nutrient reductions to offset future, more stringent Ames WPCF nutrient reductions longer term.
4. The City has effectively implemented and should continue to implement urban BMPs to achieve nutrient reductions as ancillary benefits.
5. Implementation of off-site watershed BMPs for nutrient reduction can be configured to achieve ancillary benefits including flood mitigation, erosion control, habitat restoration, source water protection, and/or recreation opportunities.
6. Off-site watershed reductions may still be useful to demonstrate leadership, make progress, and offset future Ames WPCF requirements.

Table 22 identifies the resulting off-site watershed nutrient reduction strategies.

Table 22: Potential Off-site Nutrient Reduction Strategy

Number	Potential Off-site Nutrient Reduction Strategies
1	Demonstrate commitment and progress to the 2013 Iowa Nutrient Reduction Strategy through continued implementation of urban best management practices with added emphasis on the associated watershed nutrient reductions
2	Identify and prioritize projects that demonstrate good stewardship of City property, provide multiple benefits on sites located within the City of Ames, and then provide multiple benefits on sites outside of the City of Ames.
3	Establish a goal and commit the required annual funding for implementing watershed-based practices that provide nutrient reduction and other ancillary benefits such as flood mitigation, erosion control, source water protection, habitat restoration, and recreational opportunities.
4	Register and bank credits with the Nutrient Reduction Exchange to offset potential future requirements such as water quality-based nutrient limits.
5	Support Iowa State University efforts to develop innovative and alternative watershed based nutrient reduction.

6.1.3 Watershed Alternatives

The potential sites and projects identified in Figure 15 through Figure 17 have been identified as examples to convey concepts and potential ancillary benefits for off-site watershed nutrient reduction. The examples include sites and projects on property owned by the City, within the City of Ames, and outside the City of Ames. The City has identified the prioritization criteria as shown in Table 23 for off-site watershed nutrient reduction. Table 24 identifies ancillary benefits for the example sites and projects.

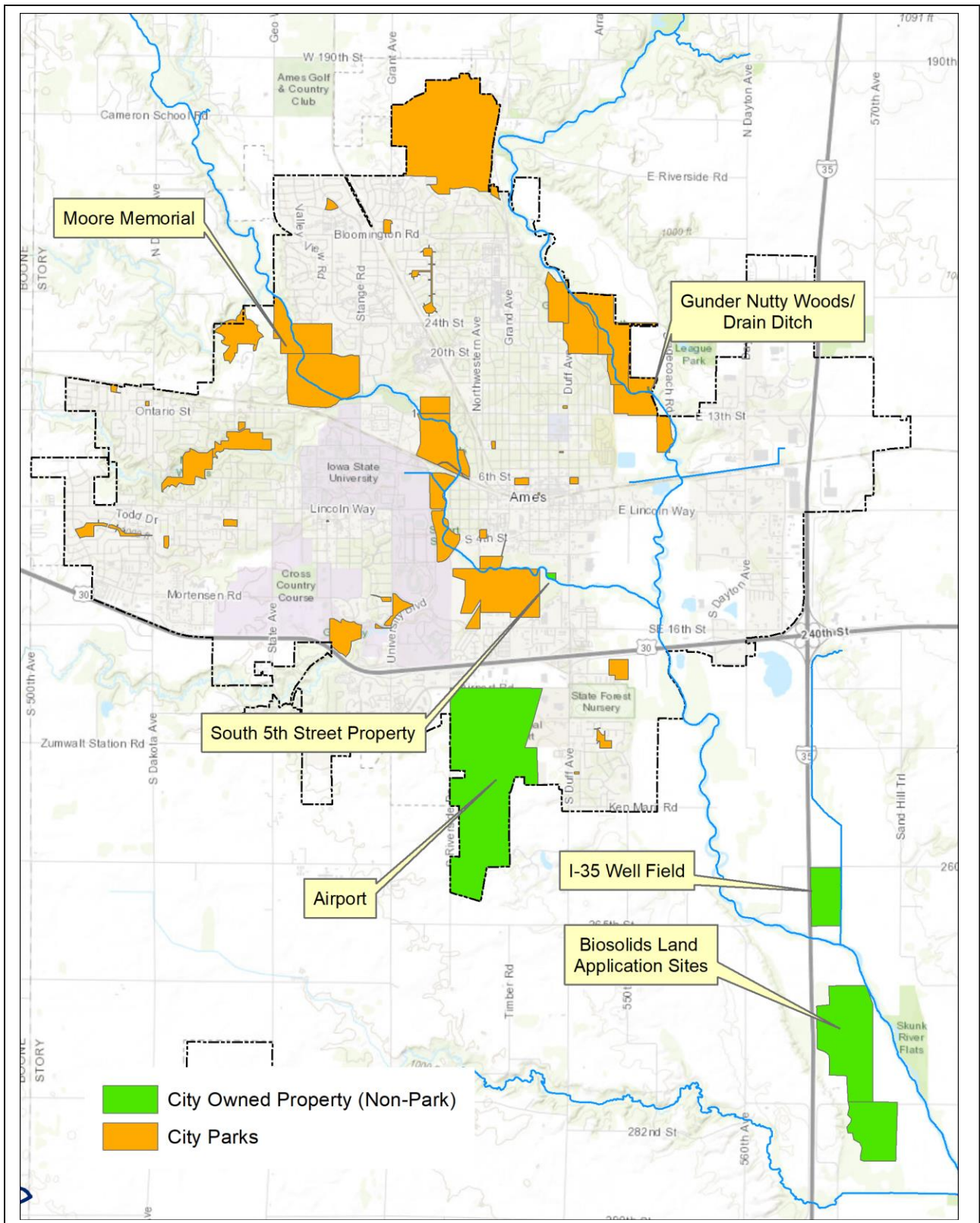

Figure 15: Off-site Nutrient Reduction Example Sites and Projects - City Property

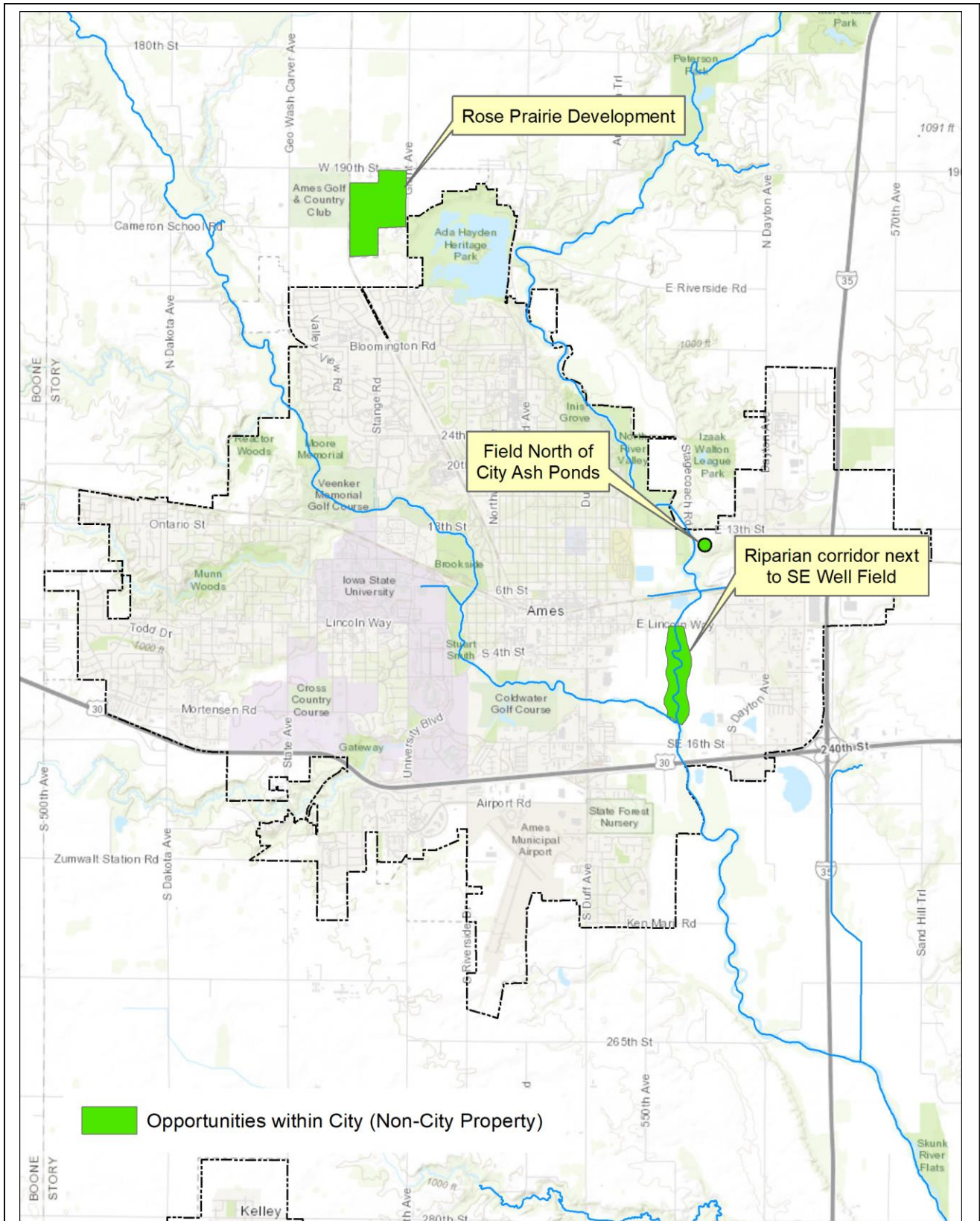

Figure 16: Off-site Nutrient Reduction Example Sites and Projects – Within City

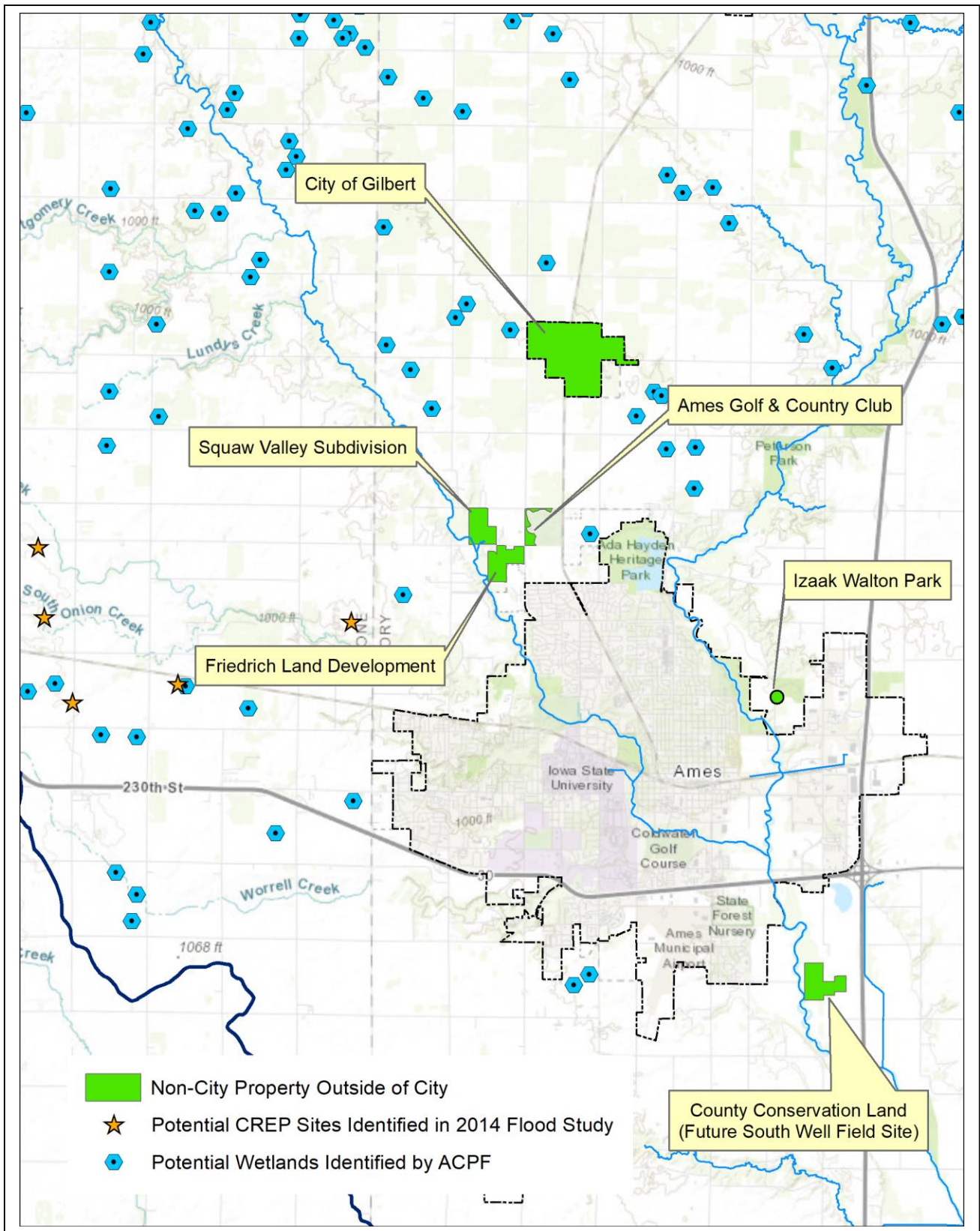

Figure 17: Off-site Nutrient Reduction Example Sites and Projects – Outside City

Table 23: Off-site Nutrient Reduction Prioritization Criteria

Category	Criteria
Location	City-owned land Within City limits Land in Upstream Watersheds
Ancillary Benefits	Flood mitigation Drinking Source Water Protection Increased Wildlife Habitat Improved Water Quality Increased Recreational Opportunities Increased hunting opportunities Other benefits
Nutrient Reduction Cost/Benefit	Lower \$/pound Removed than Ames WPCF Lowest \$/pound Removed Highest Pounds Removed
Life Cycle	Number of Years Provided Lowest Annual Maintenance Costs Lowest Life Cycle Cost

Table 24: Off-site Nutrient Reduction Example Sites and Projects

Location	Site	Potential BMPs/Project	Water Quality/Nutrient Reduction	Flood Mitigation	Erosion Control	Habitat Restoration	Water Source Protection	Recreational Opportunity
City Property	Biosolids Land Application Sites	Bioreactor, Constructed wetlands	X	X	X	X		
	Airport	Bioreactor	X					
	I-35 Well Field	CRP/Potential ISU Research	X		X	X	X	
	City Parks	Range of BMPs	X	X	X	X		X
City Property	South 5 th Street Property	Storm sewer interceptor/constructed wetland	X	X	X	X		
	Gunder Nutty Woods/Drain Ditch	Hydro modifications	X		X	X		
	Field North of City Ash Ponds	Regional stormwater detention	X	X	X	X		X
Within City of Ames	Riparian Corridor next to SE Well Field	Bike trail, wetlands, and riparian restoration	X		X	X	X	X
	Rose Prairie Development	Detention pond	X	X	X	X		X
Outside City of Ames	Ames Golf & Country Club	Reduced phosphorus application and applicable MS4 BMPs	X	X	X	X		X
	Friedrich Land Development	Friedrich Land Development	X	X	X	X		X
	Squaw Valley Subdivision	Sewer hook up	X					

Location	Site	Potential BMPs/Project	Water Quality/Nutrient Reduction	Flood Mitigation	Erosion Control	Habitat Restoration	Water Source Protection	Recreational Opportunity
	County Conservation Land (Future South Well Field)	CRP/HAP	X		X	X	X	X
	City of Gilbert	Interceptor/hook up with City sewer	X					
	Izaak Walton Park	Lake rehabilitation	X					
	CREP Wetland Sites	Constructed wetlands	X	X	X	X		X

6.2 Integrated Strategy and Implementation

The recommended nutrient reduction strategy and implementation plan for nutrient reduction for the City of Ames includes investment in both off-site watershed nutrient reductions and on-site Ames WPCF nutrient reductions. The integrated strategy, implementation plan, and impact on sewer rates are presented in the following.

6.3 Integrated Nutrient Reduction Strategy

Table 25 presents the integrated nutrient reduction strategy.

Table 25: Integrated Nutrient Reduction Strategy

Integrated Nutrient Reduction Strategy
Convert from trickling filters to alternative technology that provides additional capacity for growth and nutrient removal that achieves the goals of the 2013 Iowa Nutrient Reduction Strategy
Minimize Ames WPCF costs and associated customer rate impacts through phased implementation of alternative technology that continues to use existing trickling filter capacity as long as condition allows
Incorporate existing Ames WPCF optimization to the extent affordable and consistent with alternative Ames WPCF technology.
Demonstrate commitment through continued implementation of urban best management practices with added emphasis on associated watershed nutrient reductions
Identify, prioritize, and fund watershed nutrient reduction projects consistent with location, ancillary benefits, cost and benefit, and life-cycle cost criteria.
Register and bank watershed credits with the Nutrient Reduction Exchange to offset potentially more stringent future requirements
Support Iowa State University efforts to develop innovative and alternative watershed based nutrient reduction.

6.4 Implementation Plan

Implementation of the integrated nutrient reduction strategy entails parallel tracks to proceed with both off-site watershed nutrient reduction projects and on-site Ames WPCF improvements to achieve nutrient reduction. Both tracks are described in the following.

Watershed Nutrient Reduction. Watershed nutrient reduction includes both a continuation of historic practices to incorporate stormwater BMPs in City projects and an added commitment to additional watershed projects specifically targeted at nutrient reduction, but with other ancillary benefits. Example sites and projects were previously presented in Figure 15 through Figure 17 and summarized in Table 24.

Example sites are grouped by location on City Property, within the City of Ames, and upstream of the City of Ames. Example projects include several different practices, including: bioreactors, constructed wetlands, Conservation Reserve Program (CRP), research, hydraulic modifications, stormwater detention, and riparian buffer. Ancillary benefits in addition to nutrient reduction are identified for each example project, including flood mitigation, erosion control, habitat restoration, water quality, and recreation.

Table 23 presented location, ancillary benefit, nutrient reduction costs and benefits, and life-cycle cost criteria to prioritize and identify specific sites for off-site watershed nutrient reduction. The City's Fiscal Year 2020 *Capital Improvements Plan* includes \$200,000 per year committed for implementation to be used in conjunction with available grant funding for these types of projects. The City anticipates that this will be an ongoing element of the *Capital Improvements Plan*, but is not proposing or committing to it as part of its formal response to addressing nutrients in the Ames WPCF discharge.

Ames WPCF Nutrient Reduction. Figure 23 identifies the phased implementation plan for Ames WPCF improvements to provide 2013 Iowa Nutrient Reduction Strategy targeted reductions as well as capacity for forecast growth. The implementation plan generically refers to alternative technology rather than identify a specific technology for implementation because the three final alternatives identified in the following are similar in life-cycle costs and nonmonetary value.

- SNDN
- CAS
- GRAS

Given the similarities among the three alternatives, final selection of the specific technology can be deferred until 2022, when Phase 1 design and construction begins. Deferring final technology selection allows GRAS technology to continue to advance and provides the City an opportunity to incorporate site visits to operating facilities.

Figure 18 indicates that nutrient reduction would be achieved progressively. Limited, if any, reduction would be achieved in Phase 1, seasonal reduction would be achieved in Phase 2, and full biological nutrient reduction would be achieved in Phase 3. Two factors drive progressive reduction: 1) the need to take advantage of the remaining useful life to maximize prior investment in the existing trickling filters and 2) the existing Ames WPCF configuration, which intermingles wastewater on the front end and solids on the downstream end of existing Ames WPCF liquid treatment facilities preventing separate parallel operation of the existing trickling filters and new alternative technology.

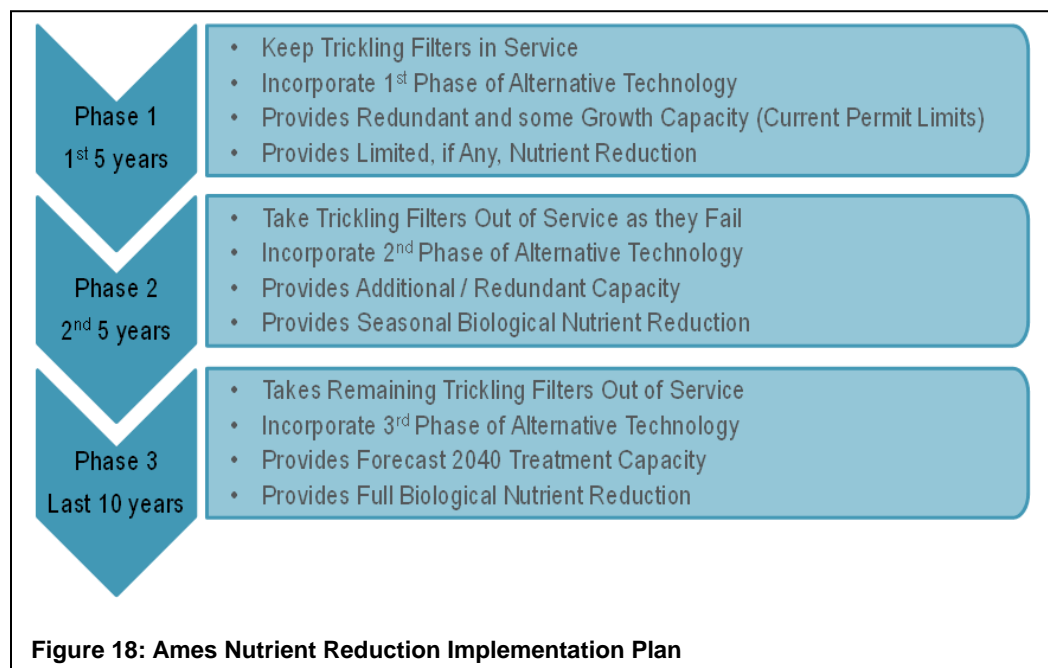

Figure 19 identifies the estimated capital cost, including both engineering and construction, for each phase in 2018 dollars. It is noteworthy that the estimate does not include any additional capital investment in the existing trickling filters to prolong their remaining useful life. Inflated to the actual construction periods, the estimated cumulative capital cost for all three phases is \$39.63 million.

6.4.1 Sewer Rate Impacts

The City of Ames Sewer Rate Policy is stated in the following passages from Chapter 28, Division III of the Ames Municipal Code.

Sec. 28.301. SEWER RATE POLICY.

It is determined and declared to be necessary and conducive to the protection of the public health, safety, welfare, and convenience of the City of Ames to collect charges from all users who contribute wastewater to the City's treatment works. The proceeds of such charges so derived will be used for the purpose of operating, maintaining, and retiring the debt for such public wastewater treatment works.

(Ord. No. 2924, Sec. 1, 5-28-85; Ord. No. 3199, Sec. 1, 9-24-92; Ord. No. 3209, Sec. 1, 12-8-92; Ord. No. 4327, 11-28-17)

Sec. 28.303. USE OF RATE REVENUE.

The user charge system shall generate adequate annual revenues to pay costs of annual operation and maintenance, including replacement, and costs associated with debt retirement of bonded capital associated with financing the treatment works which the City may by ordinance designate to be paid by the user charge system. That portion of the total user charge which is designated for operation and maintenance, including replacement of the treatment works, shall be established by this ordinance.

That portion of the total user charge collected which is designated for operation and maintenance, including replacement, shall be deposited in a separate non-lapsing fund known as the WPC Operation, Maintenance and Replacement Fund.

(Ord. No. 2924, Sec. 1, 5-28-85; Ord. No. 3199, Sec. 1, 9-24-92; Ord. No. 3209, Sec. 1, 12-8-92; Ord. No. 4327, 11-28-17)

Sec. 28.304. SEWER RATES ESTABLISHED.

(1) Each user shall pay for the services provided by the City based on its use of the treatment works as determined by water meter readings or other appropriate methods acceptable to the City.

(Ord. 4199, 11-25-14)

(2) For all users, monthly user charges shall be based on actual water usage, except where a practical method of wastewater measurement is available. If a user has a consumptive use of water, or in some other manner uses water which is not discharged into the wastewater collection system, the user charge for that contributor may be based on readings of a wastewater meter(s)

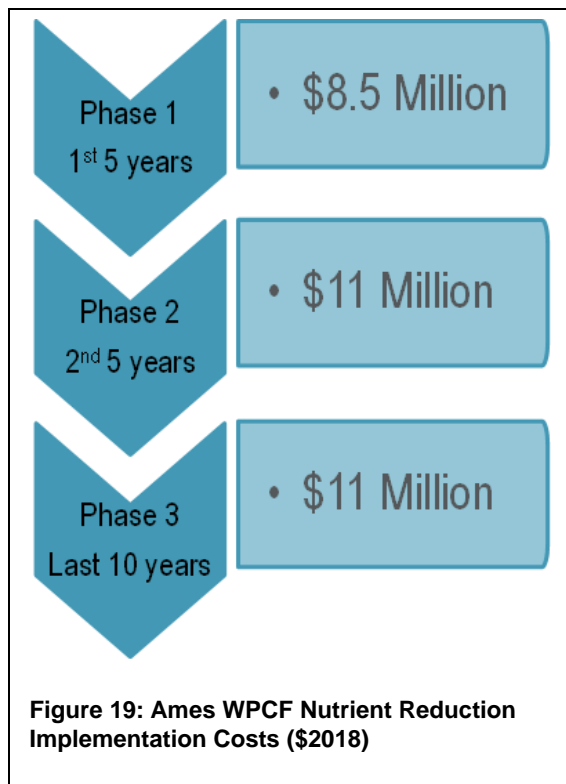

or separate water meter(s) installed and maintained at the user's expense and in a manner acceptable to the City.

(7) The City will review the user charge system at least every three years and revise user charge rates as necessary to ensure that the system generates adequate revenues to pay the costs of operation and maintenance including replacement and that the system continues to provide for the proportional distribution of operation and maintenance including replacement costs among users.

The City will notify each user at least annually, in conjunction with a regular bill, of the rate being charged for operation and maintenance including replacement of the treatment works.

(Ord. No. 3526, 6-22-99)

When setting user rates, the City uses three separate long-term planning documents.

- A City-wide 5-year Capital Improvements Plan that is formally adopted by the City Council each spring.
- A 10-year rate model that is developed for the sewer utility. This model is the basis for user rates proposed to the City Council annually. The City Council only approves the first year's rates.
- A 20-year capital projects planning document that is developed by the staff of the Water and Pollution Control Department. While not formally presented to or adopted by the City Council, this working list is used as a tool to ensure that a long-term approach is being used for planning purposes.

Because water and sewer are billed to customers on the same utility bill, the timing of rate adjustments are coordinated between water and sewer to avoid doubling up in a single year. Every year, the 10-year rate projection is shared with the City Council. While the City Council only approves rates 1 year at a time, having a long-term picture is important for the policy makers to see where utility rates are heading.

The 10-year plan for rate increases that will be presented to the City Council in spring 2019 is summarized in Table 26 and will show the following pattern of proposed rate increases.

Table 26: Ten Year Plan for Proposed Ames Water and Sewer Rate Increases

	Year 1	Year 2	Year 3	Year 4	Year 5	Year 6	Year 7	Year 8	Year 9	Year 10
	19-20	20-21	21-22	22-23	23-24	24-25	25-26	26-27	27-28	28-29
Water Fund	7%		9%		9%		9%		9%	
Sewer Fund		5%		5%		6%		6%		5%

The proposed sewer rate increases shown in Table 26 are based on incorporation of the recommendations from the Nutrient Reduction Feasibility Study. Note that the recommendation for achieving the goals of the 2013 Iowa Nutrient Reduction Strategy involves the integrated watershed and Ames WPCF integrated strategy presented herein, notably annual investment in watershed nutrient reductions and three-phase implementation of Ames WPCF nutrient reductions over the next 20 years.

It is assumed that each of the three Ames WPCF phases will be financed using separate loans from the Clean Water State Revolving Fund. Only the debt service for Phase 1 (debt service beginning in Year 6) shows in the rate model. The model assumes that construction for Phase 2 will occur in Year 10, with debt service beginning in Year 11 (outside the horizon of the model).

Phase 3 is likewise outside the planning horizon of the rate model. The rate model inflates the costs from this study, which are presented in 2018 dollars, forward at an assumed inflation factor of 3.5 percent per year.

To evaluate the impact of adopting the recommendations from the Ames Nutrient Reduction Feasibility Study, the rate model was ran twice; once with the debt service for the Phase 1 State Revolving Fund loan and \$200,000 per year of cash-funded watershed improvements included, and again with those costs excluded. Table 27 shows the results of the comparison.

Table 27: Ames Sewer Rate Increases With and Without Nutrient Reduction Strategy

	Year 1	Year 2	Year 3	Year 4	Year 5	Year 6	Year 7	Year 8	Year 9	Year 10
	19-20	20-21	21-22	22-23	23-24	24-25	25-26	26-27	27-28	28-29
Sewer Fund Rates Needed WITHOUT NRS		3%		3%		5%		6%		5%
Sewer Fund Rates Needed WITH NRS		5%		5%		6%		6%		5%

At the end of 10 years, the incremental cost of implementing Phase 1 is \$1.70 per month for a residential customer using 600 cubic feet of water per month (\$36.35 per month versus \$34.65 per month). Each of the second and third phases would likely have rate increases that are similar in magnitude to Phase 1, with the combined differential being on the order of 15 percent.

Attachment A – Ames WPCF Optimization Options

Ames Water Pollution Control Facility (WPCF) optimization options focus on ways to integrate biological phosphorus removal by creating anaerobic conditions in the return activated sludge (RAS) reaeration tanks and providing a carbon source. To achieve anaerobic conditions, denitrification of the RAS is necessary, and, coincidentally, would achieve some nitrogen removal simultaneously with phosphorus removal. The carbon could be supplied either by diversion of some primary effluent around the trickling filters or by providing filtrate from primary sludge thickening.

Currently, waste activated sludge is co-thickened with primary sludge in the primary clarifiers and pumped directly to the anaerobic digesters. To operate biological phosphorus removal, waste activated sludge must be handled separate from primary sludge. Otherwise, co-thickening in the primary clarifier would most certainly result in stored phosphorus release to the liquid stream, because any extended contact between the WAS and raw influent results in stored phosphorus release to the degree that volatile fatty acids would be present. The phosphorus release is quick with only 15 to 30 minutes contact time required, during which the raw influent volatile fatty acids are consumed by non-beneficial phosphorus release and no longer available as a carbon source for biological phosphorus removal in the RAS tanks. Therefore, all optimization options need to have dedicated WAS thickening.

Six optimization options were identified for the Ames WPCF to target biological phosphorus removal and produce lower effluent phosphorus concentrations. All six options include various combinations of flow routing, repurposing of facilities, separate solids thickening, and modified operations to create an anaerobic zone with sufficient carbon source for phosphorus uptake. The six options, model predicted performance, and comparative construction costs are described in the following.

Option 1: Biological Phosphorus Removal in RAS Anaerobic Zone and Primary Effluent Diversion

For option 1, the air is turned off in two-thirds of the RAS reaeration tanks. Submerged mechanical mixer would be added to keep the biomass in suspension. The mixers may be operated intermittently to achieve deep anaerobic conditions in the sludge when mixers are off. Figure A-1 shows the schematic for this option. Roughly 20 percent of the primary effluent would be diverted to the anaerobic RAS zone.

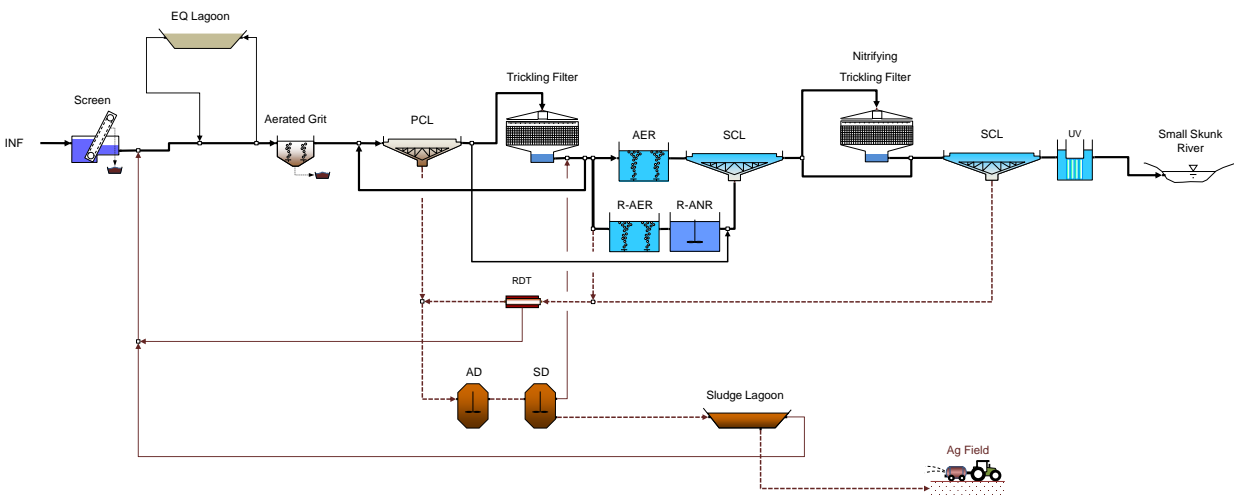

Figure A-1: Schematic for Option 1, RAS Anaerobic Zone and PE Diversion

Option 2: Biological Phosphorus Removal in RAS Anaerobic Zone, Primary Effluent Diversion Dedicated Primary Sludge Thickening

Option 2 builds on Option 1 by adding dedicated primary sludge thickening. The schematic in Figure A-2 shows a rotating drum thickener, but a conventional gravity thickener or thickening centrifuge would work as well.

The purpose of the dedicated primary sludge thickening is to add an interface from which additional VFA can be diverted to the anaerobic RAS zone. Even without the added retention of thickening in the primary clarifier, primary sludge has high concentration of VFA and can range depending on the season and conditions in the collection system from 100 to 1,000 milligrams per liter (mg/L).

One added advantage of dedicated thickening is better thickening performance, which increases the digester capacity and reduces the need for decanting of the secondary digesters, thus cutting back on the recycle load.

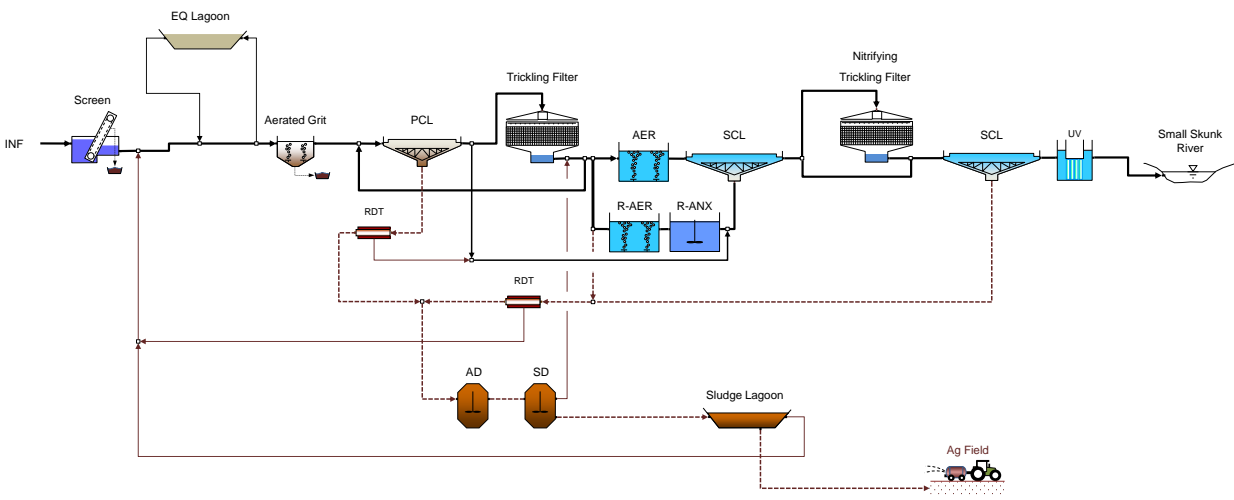

Figure A-2: Schematic for Option 2, RAS Anaerobic Zone and Sludge Thickening

Option 3: Extended RAS Anaerobic Volume with Primary Effluent Diversion

Option 3 builds on Option 1, but uses all of the RAS reaeration tanks for the RAS anaerobic zone. This provides additional anaerobic retention time for both phosphorus release and RAS fermentation, but it reduces the aerobic retention time needed for phosphorus uptake.

Figure A-3 shows the schematic for this option.

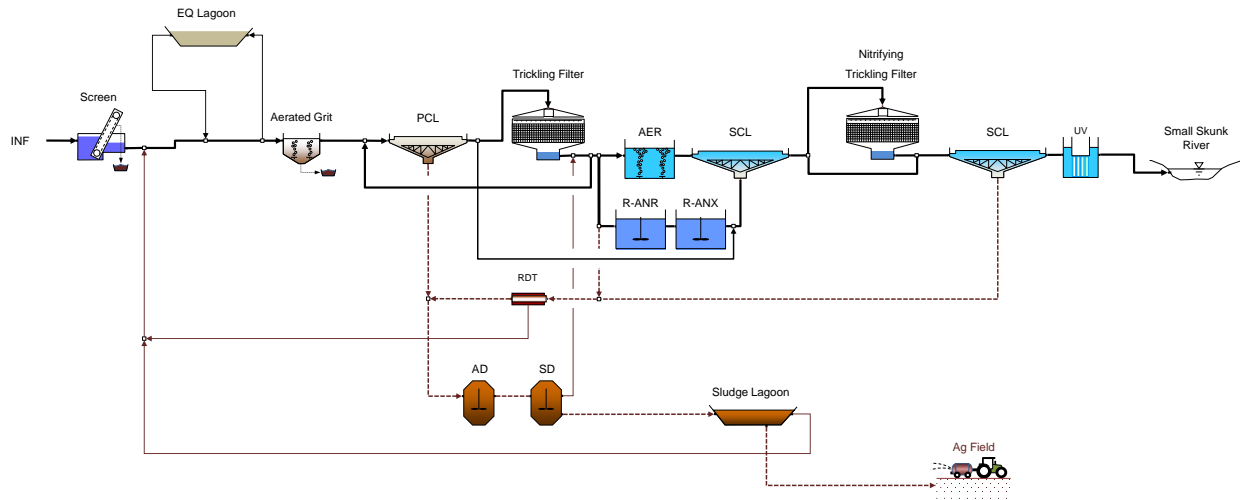

Figure A-3: Schematic for Option 3, Extended RAS Anaerobic Zone

Option 4: Extended RAS Anaerobic Volume with Primary Effluent Diversion and Primary Sludge Thickening

Option 4 builds on Option 2. It features both the primary effluent diversion and dedicated primary sludge thickening to provide additional VFA. This option may be feasible without the primary effluent diversion due to the combination of extended anaerobic RAS retention time and VFA from primary sludge thickening. Eliminating the primary effluent diversion would increase the hydraulic retention time (HRT). This sub-option may be explored further if Option 4 is selected. Figure A-4 shows the schematic for this option.

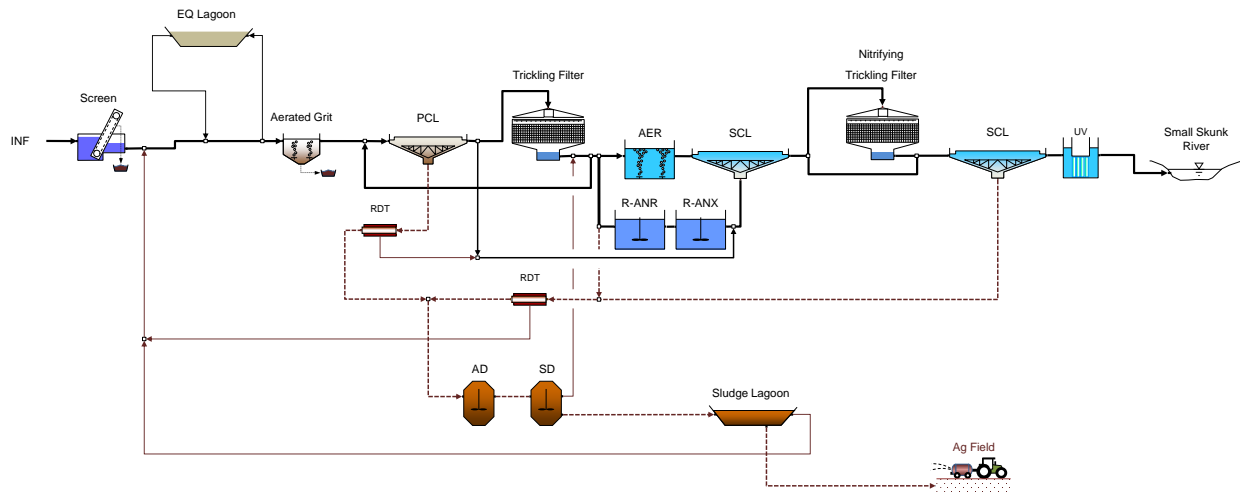

Figure A-4: Extended RAS Anaerobic Zone and Primary Sludge Thickening

Option 5: Converting one Primary Clarifier to Anaerobic RAS Tank

The existing RAS reaeration volume is small and expected to limit the maximum biological phosphorus uptake. The Ames WPCF has more than sufficient primary clarifier capacity such that one could be repurposed to hold RAS. This would provide an additional 250,000 gallons of volume. Two-thirds of the RAS reaeration volume converted to anaerobic in Option 1 provide 640,000 gallons of volume for reference. Thus, the volume of one primary clarifier is not sufficient to eliminate converting some of the RAS reaeration tanks to anaerobic.

This option includes dedicated thickening for both waste activated sludge and primary sludge, as well as primary effluent diversion and VFA addition through primary sludge thickening return. If this option was selected, an additional sub-option can be explored to minimize the scope of the modifications. Figure A-5 shows the schematic for this option.

The conversions of one primary clarifier does not have to be permanent and it could be returned to its original purpose when needed in the future.

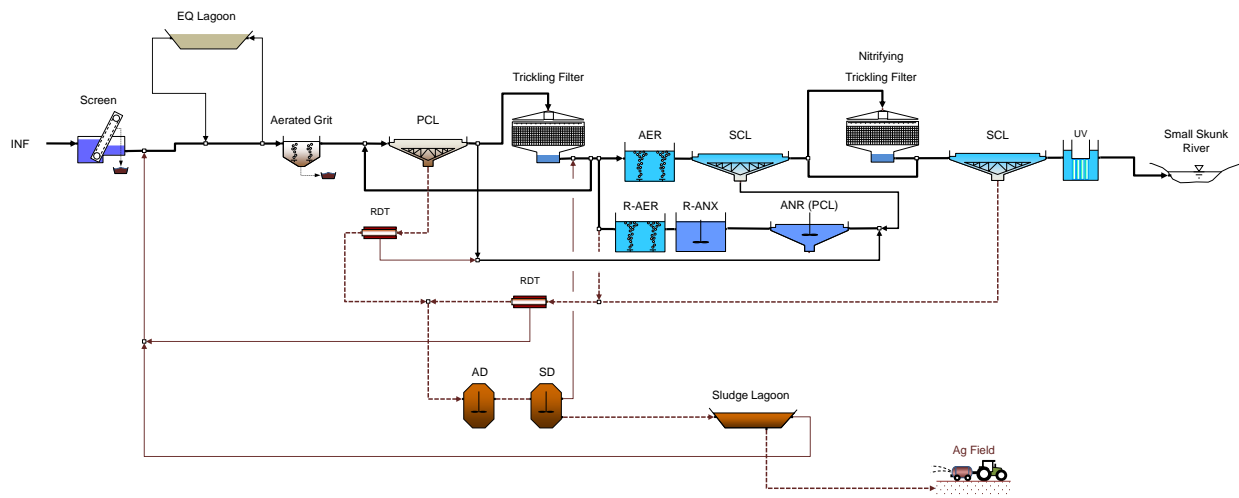

Figure A-5: Option 5: Converting One Primary Clarifier to Anaerobic RAS Tank

Option 6: Converting One Secondary Clarifier to Anaerobic RAS Tank

Option 6 is identical to Option 5, except instead of a primary clarifier, one secondary clarifier is repurposed. The advantages of Option 6 over Option 5 is that there is more excess secondary clarifier capacity, the secondary clarifiers are adjacent to the RAS reaeration tanks, and they provide more volume (450,000 gallons). Figure A-6 shows the schematic for this option.

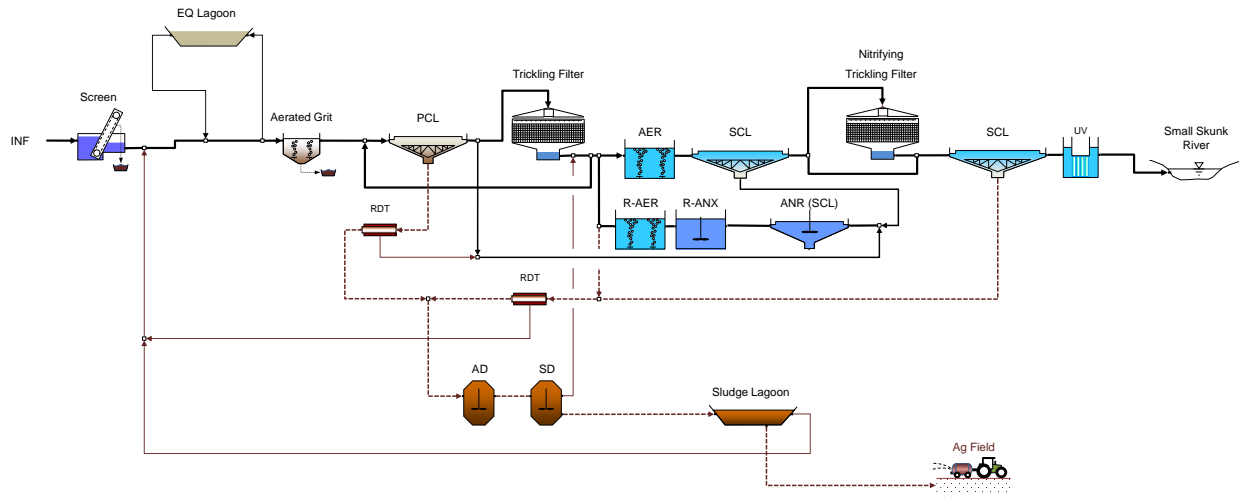

Figure A-6: Option 6: Converting One Secondary Clarifier to Anaerobic RAS Tank

Comparison of Nutrient Reduction Option

Table A-1 identifies the GPS-X™ wastewater modeling software predicted effluent quality for each of the six options. Comparing the results, all options achieve some phosphorus and nitrogen reduction. The nitrogen reduction is a function of having to first remove the nitrate to establish anaerobic conditions. Option 2 shows the lowest effluent phosphorus and nitrogen and its implementation is relatively simple; however, it includes dedicated and separate thickening of primary and waste activated sludge.

Table A-1: Ames WPCF Optimization Model* Predicted Effluent Summary

Option	Flow (MGD)	PO4-P	TP	NH4-N	TN	TSS
Existing	6.0	3.2	3.3	0.1	24.0	11
1	7.0	1.2	1.4	2.7	27.5	7
2	7.0	1.0	1.2	2.8	27.4	6
3	7.0	1.1	1.5	10.0	27.9	9
4	7.0	1.0	1.5	10.0	28.0	9
5	7.0	1.4	1.8	2.5	24.5	9
6	7.0	5.6	2.7	9.9	28.0	9

*GPS-X™ Wastewater Modeling Software

Note. All values in milligrams per liter (other than flow in million gallons per day (MGD))

Table A-2 identifies the comparative construction cost, model predicted phosphorus reduction, and relative cost per pound of phosphorus removed for each of the six optimization options. Comparing the relative costs shows that some options more cost-effectively reduce phosphorus than other options. The identified construction costs are estimates for comparative purposes only and do not include engineering costs. The identified percent of total phosphorus reductions are annual averages beyond the percent total phosphorus reduction currently achieved at the Ames WPCF. The reported pounds of total phosphorus reduction reflects a 20-year period at an average flow rate of 7.0 MGD.

It is significant to note that the Ames WPCF is currently achieving an estimated annual average reduction of approximately 28 percent (from 4.6 to 3.3 mg/L). As such, options shown in Table A-2 with estimated phosphorus reductions of 45 percent or greater would provide the Nutrient Reduction Standard required 75 percent reduction even though the estimated effluent phosphorus concentration would still be above 1 mg/L.

Construction costs range from just under \$5 million to just over \$10 million. Options 1 and 3 show the lowest cost per pound of phosphorus reduction with Options 2 and 4 with the next lowest costs per pound. All four of these options would result in an estimated overall reduction of greater than 75 percent. However, as shown in Table A-1, none of the options provide much, if any, additional nitrogen reduction beyond the estimated annual average nitrogen reduction of 34 percent (from 36.3 to 24.0 mg/L) currently achieved at Ames WPCF. In fact, in optimizing for phosphorus reduction, all four of the lowest cost options actually result in a slight increase in effluent nitrogen concentration.

Table A-2: Nutrient Reduction Option Comparative Costs

Option	Construction Cost	Effluent TP	% TP Red.	TP Red	Relative Cost
		mg/L	%	lb	\$/lb TP
1	\$4,850,000	1.4	58%	809,800	\$6
2	\$8,325,000	1.2	64%	895,000	\$9
3	\$4,850,000	1.5	55%	767,200	\$6
4	\$8,325,000	1.5	55%	767,200	\$11
5	\$10,575,000	1.8	45%	639,300	\$17
6	\$9,325,000	2.7	18%	255,800	\$36
7	\$9,450,000	2.6	21%	298,400	\$32

Nitrogen removal performance will be similar to existing Ames WPCF nitrogen removal performance.