

ITEM # 10  
DATE 05-26-15

**COUNCIL ACTION FORM**

**SUBJECT: ENCROACHMENT PERMIT FOR SIGN AT 2810-2812 WEST STREET**

**BACKGROUND:**

West Street Deli has requested an encroachment permit to allow a new sign to encroach over the City right-of-way.

The proposed sign is 3.05 square feet and will project approximately 3.3 feet off of the building. The encroachment of the sign should not impair pedestrian movement or the operation of the road way.

The requirements of Section 22.3 of the *Municipal Code* have been met with the submittal of a hold-harmless agreement signed by the property owner and the applicant, and a certificate of liability insurance coverage which protects the City in case of an accident. The fee for this permit was calculated at \$25, and the full amount has been received by the City Clerk's Office.

**ALTERNATIVES:**

1. Approve the request.
2. Deny the request.

**MANAGER'S RECOMMENDED ACTION:**

It is the recommendation of the City Manager that the City Council adopt Alternative No. 1, thereby granting the encroachment permit for the sign.



## APPLICATION FOR ENCROACHMENT PERMIT

An Encroachment Permit approved by the Ames City Council is required for anything of a "fixed character" which is "upon, over or under" the surface of any "street, alley or sidewalk."

Address of Encroachment: 2810-2812 WEST STREET

Type of Encroachment: BLADE SIGN  
(If the encroachment is a sign, please apply for a sign permit through the Inspections Division).

Name of Applicant: WEST STREET DECI, INC

Address: 2810-2812 WEST ST, P.O. Box 1905, AMES, IA 50010

Applicant's Home Phone: 515 232-8893 Work or Cell Phone: 515 290-7280

Owner of Building: MOTHER LODGE ENTERPRISES, INC

Owner's Address: 3213 WEST ST AMES, IA 50014

Owner's Home Phone: 515 291-7000 JOE Work or Cell Phone: 515 290-7719 DAVE

These items must be submitted with your application prior to approval of the permit:

1. An Encroachment Permit Agreement approved as to form by the City Attorney and signed by the owner of the building where the encroachment will occur. (Obtained from the City Clerk's Office).
2. A sketch of the encroaching item (i.e., sign, canopy, awning, etc.) drawn to scale.
3. A sketch showing the placement of the encroaching item on the property.
4. An insurance certificate with comprehensive general liability coverage in an amount of not less than \$500,000 combined single limit naming the City of Ames as an additional insured on the policy. Said certificate must be accompanied with a copy of Endorsement CG 2013.
5. A fee to be determined by the City's Building Official. The fee is \$1.00 per square foot of the encroachment or a minimum of \$25.00.

Applicant's Signature: Don Sprenner, Pres

Owner's Signature (If Different): David Blumby, Secy/Treas



CITY OF  
**Ames**<sup>™</sup>  
INSPECTIONS

**SIGN PERMIT APPLICATION**

Fire/Inspections Division  
515 Clark Ave, Room 205, Ames, IA 50010  
515-239-5153 FAX 515-239-5261  
www.cityofames.org/inspections

Project Address 2810-2812 WEST STREET

Applicant is:  Property Owner  Tenant  Contractor

Name WEST STREET DELI, INC Phone (515) 290-7280

Company BRUCE RUNNER Email \_\_\_\_\_

Mailing Address P.O. Box 1905, AMES, IA 50010-1905

If contractor, provide property owner/tenant name \_\_\_\_\_

If contractor, provide State of Iowa Contractor Registration No. \_\_\_\_\_

Type of Sign:  Ground  Wall  Awning and Canopy  Portable  Other \_\_\_\_\_

Permanent sign  Temporary sign

Electronic Message:  Yes  No (Flashing signs are prohibited)

Illuminated:  Yes  No

Illumination:  Internal  External (If external, attach lighting specifications including lumens)

New electrical:  Yes  No (Permit required for new electrical)

Distance between faces: 22" (30 inches or greater, include both faces for sq footage)

Square footage (per each face): 11.2

Height above grade (top of sign): 17' Height above grade (bottom of sign): 14'

Setback from property line: NA (ground signs only)

Applicant Signature *Bruce Runner* Date 5/20/15

Owner Signature *[Signature]* Date \_\_\_\_\_

\*Signature is required to process this permit

**FOR OFFICE USE**

Fee:  \$63.85 Non-Illuminated  \$90.65 Illuminated  No Permit Needed

IDOT approval required?  Yes  No

Flood Plain Development Permit Required:  Yes  No Zoning District: NC

Encroachment Permit required?  Yes  No

Approved by \_\_\_\_\_ Date \_\_\_\_\_ Permit No \_\_\_\_\_

- Sign permit approved, pending approval of encroachment permit.  
5/21/15  
SM

# PROOF

ATTENTION! It is your responsibility to read and check this proof carefully and thoroughly. By approving this proof, you are accepting all responsibility for undetected errors. Changes made to the proof may result in delays and additional costs. If proof is not approved within 30 days, the customer may be charged for creative time. This design is the sole property of Sign Pro. Any duplication in whole or in part without the express written consent of Sign Pro is strictly prohibited.

Order Date:  
05/05/15

Customer:  
West Street Deli

Ordered by:  
Drew

Job #:

Due Date:

## JOB NOTES

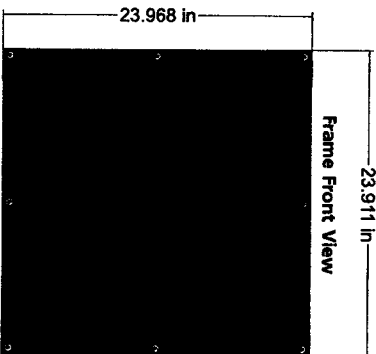
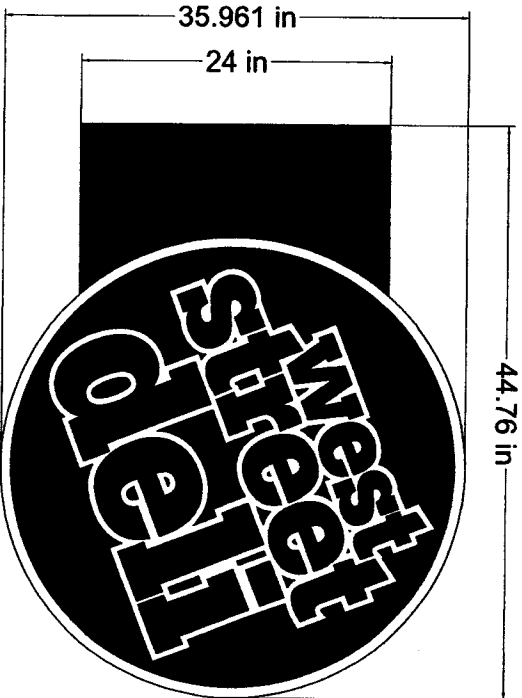

Frame Front View

Qty: 1  
36"x44.8" dibond blade sign  
Inkjet print on 3165RA w/laminate  
2 sided with cut to shape 36" circle  
Installed

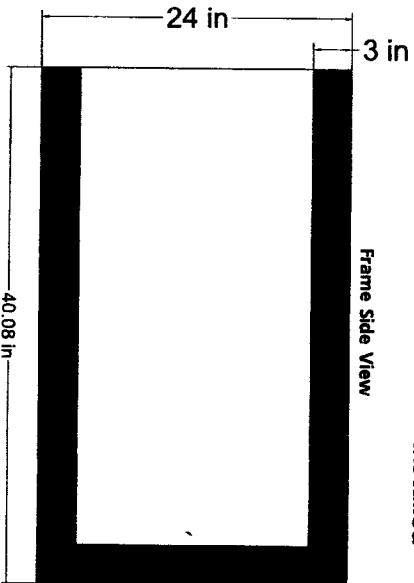

Frame Side View

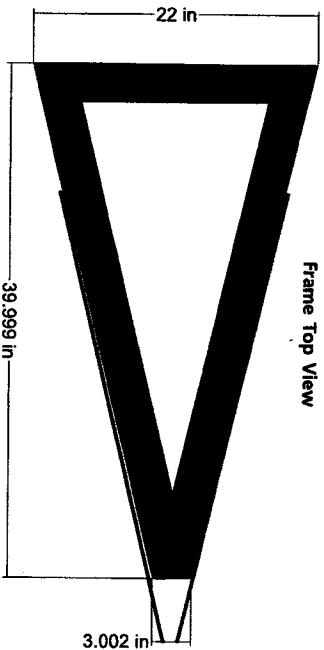

Frame Top View



619 S. 4th Street  
Ames, Iowa 50010  
515-232-4500 • SignProAmes.com

PAGE 1/1

DESIGN: \_\_\_\_\_ 1hr

PRODUCTION: \_\_\_\_\_

INSTALL: \_\_\_\_\_

CUSTOMER CALLED: \_\_\_\_\_

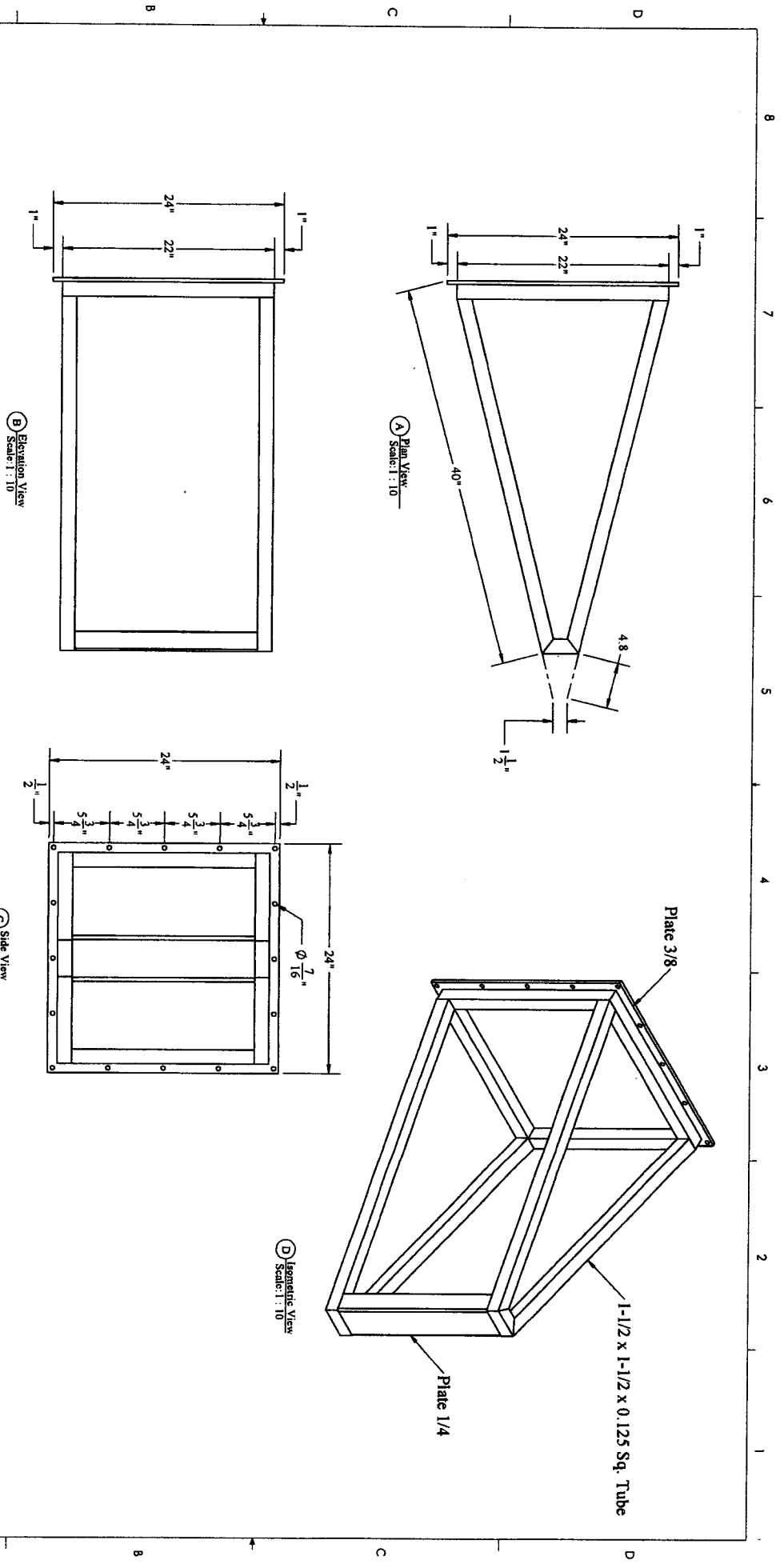

<p><b>PROHIBITARY AND CONFIDENTIAL</b></p> <p>THE ORIGINAL COPY CONTAINED IN THIS DRAWING IS THE SOLE PROPERTY OF SARGENT METAL FABRICATING. ANY REPRODUCTION IN PART OR AS A WHOLE WITHOUT THE WRITTEN PERMISSION OF SARGENT METAL FABRICATING IS PROHIBITED.</p>		<p><b>UNLESS OTHERWISE SPECIFIED:</b></p> <p>DIMENSIONS ARE IN INCHES</p> <p>TOLERANCES:</p> <p>FRACTIONS: ± 1/16" CHG ± BEND ± 1/16"</p> <p>ANGLES: ± 0.1° CHG ±</p> <p>TWO PLACE DECIMAL ±</p> <p>THREE PLACE DECIMAL ±</p>															
		<p>DATE: 5-18-15</p> <p>DRAWN BY: ZTA</p> <p>CHECKED BY: JA</p>	<p>NAME: ZTA</p> <p>DATE: 5-18-15</p>														
<p><b>REVISIONS:</b></p> <table border="1"> <tr> <th>REV.</th> <th>DESCRIPTION</th> </tr> <tr> <td>Rev. 1</td> <td>QTY: 1</td> </tr> <tr> <td>Rev. 2</td> <td></td> </tr> <tr> <td>Rev. 3</td> <td></td> </tr> <tr> <td>Rev. 4</td> <td></td> </tr> <tr> <td>Rev. 5</td> <td></td> </tr> <tr> <td>Rev. 6</td> <td></td> </tr> </table>		REV.	DESCRIPTION	Rev. 1	QTY: 1	Rev. 2		Rev. 3		Rev. 4		Rev. 5		Rev. 6		<p><b>COMMENTS:</b></p>	
REV.	DESCRIPTION																
Rev. 1	QTY: 1																
Rev. 2																	
Rev. 3																	
Rev. 4																	
Rev. 5																	
Rev. 6																	
<p><b>MATERIALS:</b></p> <p>Aluminum</p> <p>TRUSS Powder Coat Flat Black</p> <p>DO NOT SCALE DRAWING</p>		<p><b>SIZE:</b> B</p> <p><b>DWG. NO.:</b> SB-3</p> <p><b>SCALE:</b> 1:10</p> <p><b>WEIGHT:</b> 36.6736</p>															
<p><b>WEST STREET DELI SIGN</b></p> <p><b>Sign Pro</b></p> <p><b>Ames, IA</b></p>		<p><b>REV:</b> 0</p> <p><b>SHEET 1 OF 1</b></p>															

**SARGENT**  
 METAL FABRICATING  
 650 ARRASWORTH TRAIL  
 AMES, IA 50010-9022  
 (515)-232-1535

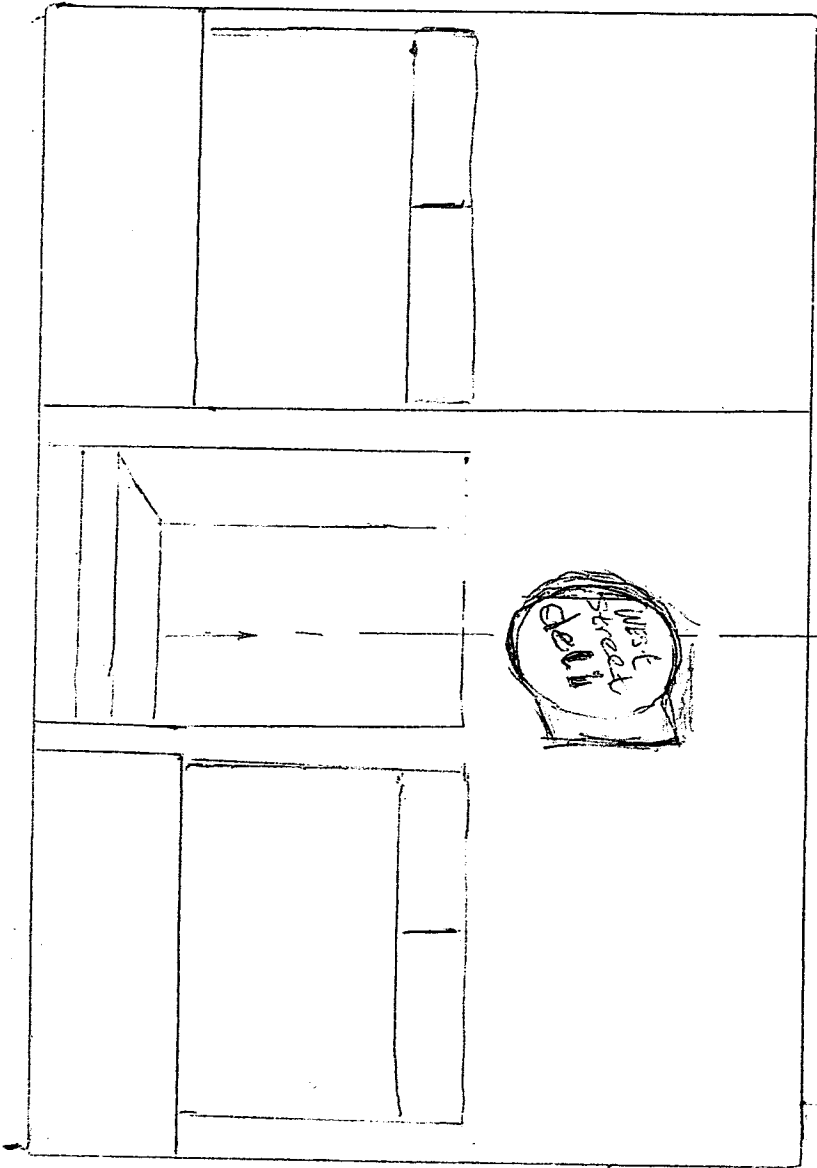

CENTERED  
ABOVE COVE  
ENTRANCE